

Leitz LABORLUX 11 POL S and 12 POL S
One sophisticated design
for two polarising microscopes

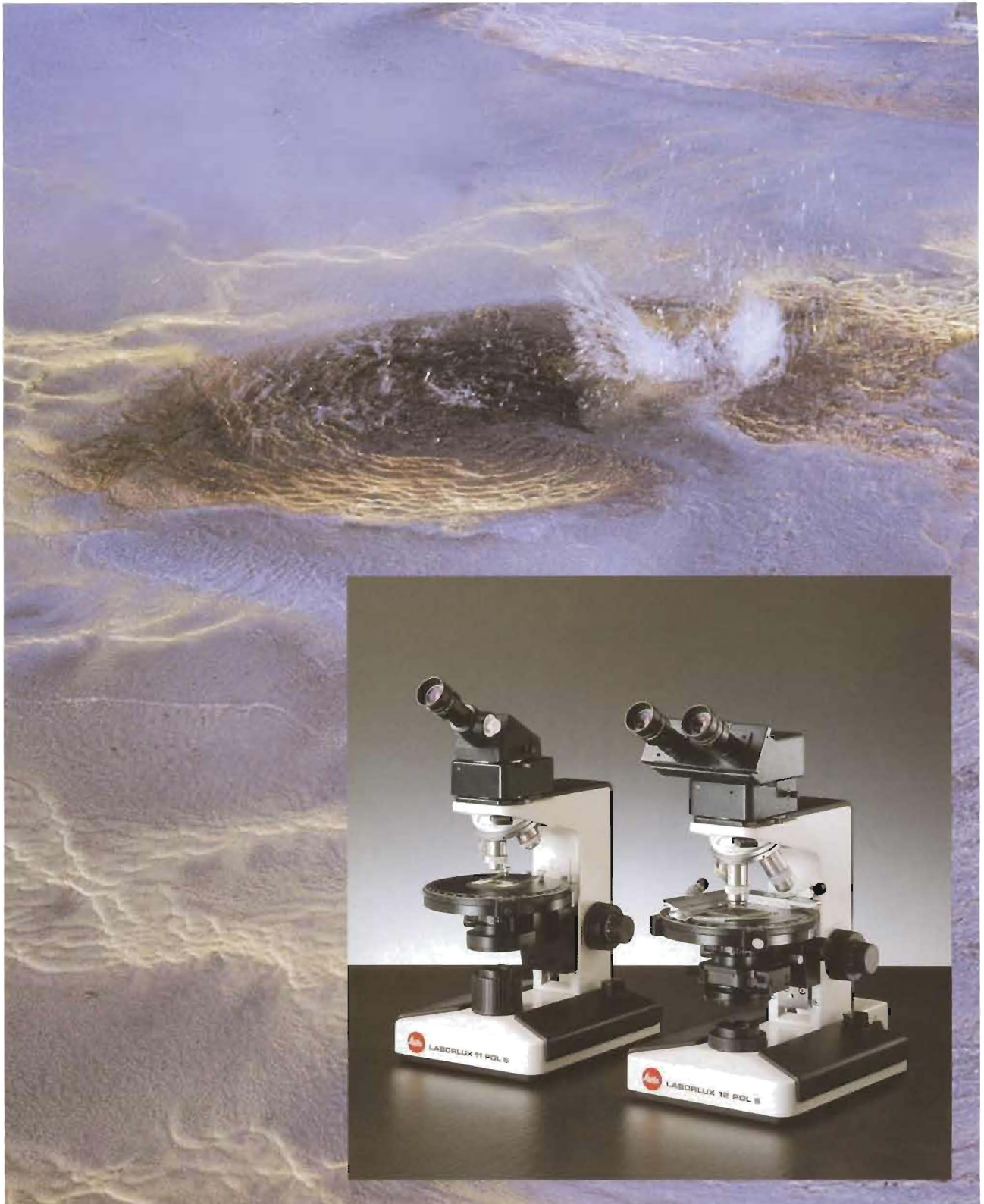

LABORLUX 11 POL S and 12 POL S are further developments of the popular LABORLUX 11 POL and 12 POL microscopes. Used for polarising optic investigations and measurements in transmitted and incident light, both microscopes have the same basic modular design, enabling the user to add equipment to suit his or her specific requirements. In this way, even large outfits have a favourable price-performance ratio.

The difference between the two lies in the fixed (11 POL S) and interchangeable (12 POL S) object stages, condensers and light sources for transmitted light illumination. Besides the excellent optical performance of the strain-free objectives, other convincing features are user-friendliness, component versatility, great stability and a high standard of workmanship.

Illustrations on facing page:

Fumaroles in Iceland

Photo: Dr. W. Patzelt, Wetzlar.

LABORLUX 11 POL S, Pol tube P 42/30 B, Intermediate tube 90, built-in illumination.

LABORLUX 12 POL S, Pol tube S 20, Intermediate tube 90 B, multi-format object guide, lamphousing 20.

Illustrations on this page:

Polished section of "Black smoker" rock, Galapagos rift, 0° 45,91' N, 85° 54,86' W, 2570 metres below sea level.

Oil immersion photos: a) one polariser. b) crossed polarisers.

Prof. Dr. W. Tufar, Philipps-Universität Marburg.

c) melt specimen, photo: Dr. W. Patzelt, Wetzlar.

Front cover:

WILD aerial photo: Wolf creek meteorite crater in Western Australia, Scale 1 : 8000.

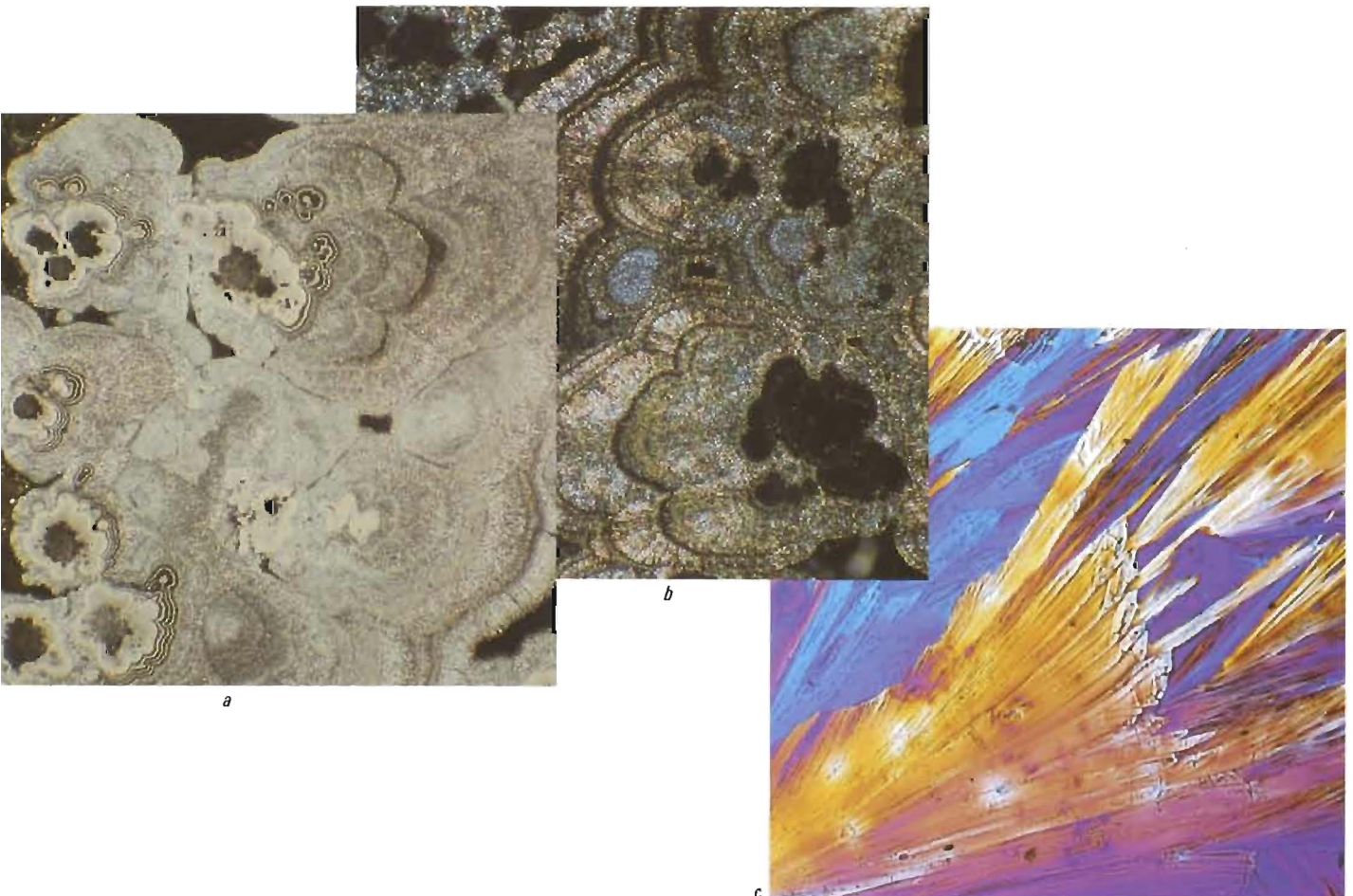

Outstanding stability

The stands of the Leitz LABORLUX 11 POL S and 12 POL S are made of corrosion-free cast aluminium. Their internal ribbing provides extra stability to allow the attachment of a wide variety of accessories.

The controls and the viewing height and angle of the observation tubes incorporate the results of the latest ergonomic research.

All controls subject to extreme mechanical wear are made especially resistant. The quick-change mounts for the observation and intermediate tubes are hard chromium plated, for example.

The coarse and fine focus controls have precision coaxial dual-knob adjustment. The drive mechanism is maintenance-free and insensitive to environmental influences.

The optics for transmitted light illumination and the transformer for the 10 W / 20 W halogen lamps are housed in the large base of the LABORLUX 11 POL S stand, where they are protected from dust. The illumination can be instantly changed from transmitted to incident light (two lamphousings 20) with the toggle switch on the back of the stand.

The LABORLUX 12 POL S can be fitted with either the lamphousing 20 or 104, which are also used for the incident light outfits. The standard light source for

fluorescence microscopy is the 50 W ultra high-pressure Hg lamp. The Hg 100 W and Xe 75 W d. c. lamps are mainly used for photometry.

Intermediate tubes for transmitted light

When transmitted light objectives of tube length 160 mm are used, an intermediate tube is required. This contains a removable analyser, and in the B* outfit a Bertrand lens for binocular conoscopy. In the integrated tube lens system with the magnification factor 1 x the light path is parallel, eliminating the risk of image displacement when the compensators are pushed in and out.

Intermediate tube 90

This is suitable for monocular orthoscopy and conoscopy when combined with the Pol observation tube P, or for binocular orthoscopy when used with the S and FSA tubes. The disengageable analyser is at an angle of 90° to the polariser.

Intermediate tube 90 B / 360 B*

Used with the S, FSA and FSA-R tubes for binocular orthoscopy and conoscopy. The disengageable Bertrand lens is centerable and coupled with a pinhole stop for the conoscopy of small grains. The smallest grain diameter which can be isolated with both intermediate tubes is about 50 μm using the 40 : 1 objective, about 40 μm with the 50 : 1 objective and about 20 μm with the 100 : 1 objective.

The intermediate tube 90 B has a non-rotatable push-in analyser. The analyser of the intermediate tube 360 B has 360° rotation and a vernier reading of 0.1°. When the analyser is disengaged, the neutral density filter automatically moves into the light path for brightness compensation.

* Bertrand lens



Fig. 2
LABORLUX 12 POL S, Pol tube S 20, intermediate tube 360 B,
multi-format object guide, Pol condenser PLK, lamphousing 104.

Observation tubes

These have a viewing angle of 30° for comfortable viewing. A birefringent quartz plate is built into the binocular observation tubes to prevent disturbing colour interference when the analyser is disengaged.

Pol tube P 42 / 30

for monocular orthoscopy and conoscopy. The built-in centerable Bertrand lens and the pinhole stop can be independently engaged and disengaged. The smallest grain diameter which can be isolated with the P tube is about $85 \mu\text{m}$ using the 40:1 objective, about $70 \mu\text{m}$ with the 50:1 objective and about $35 \mu\text{m}$ with the 100:1 objective.

Pol tube S 20

for binocular orthoscopy and conoscopy.

Pol phototube FSA 20

This tube combines the functions of a binocular observation tube and a phototube. The change in mechanical tube length occurring when the interpupillary distance is

adjusted is automatically compensated. The image is therefore in focus both in the viewing and in the film plane, so it is possible to check the photographic setting for Leitz and Wild camera attachments by looking through the observation tube.

The integrated beam splitting system of this tube permits three different light paths.

Pol phototube R FSA 20

By means of a triple prism, the measuring diaphragm can be seen at the same time as the images of the object and of the field diaphragm during measurement with the LEITZ MPV microscope photometer. If the Leitz ORTHOMAT® E camera system is used, the outlines of the various photo formats and the movable metering spot are optically superimposed on the image in the observation tube.

Tube 0

Straight monocular tube for low-cost and simple mounting of cameras with focusing telescope such as the WILD MPS camera system.

Fig. 3 Lignite mining in the Rhineland. Photo: Prof. Dr. W. Tufar, Philipps-Universität Marburg.



A choice of vertical illuminators to detect even the weakest anisotropy effects

Fig. 4: El Guezzam sandstone formation in the Algerian Sahara, photo Dr. W. Patzelt, Wetzlar.

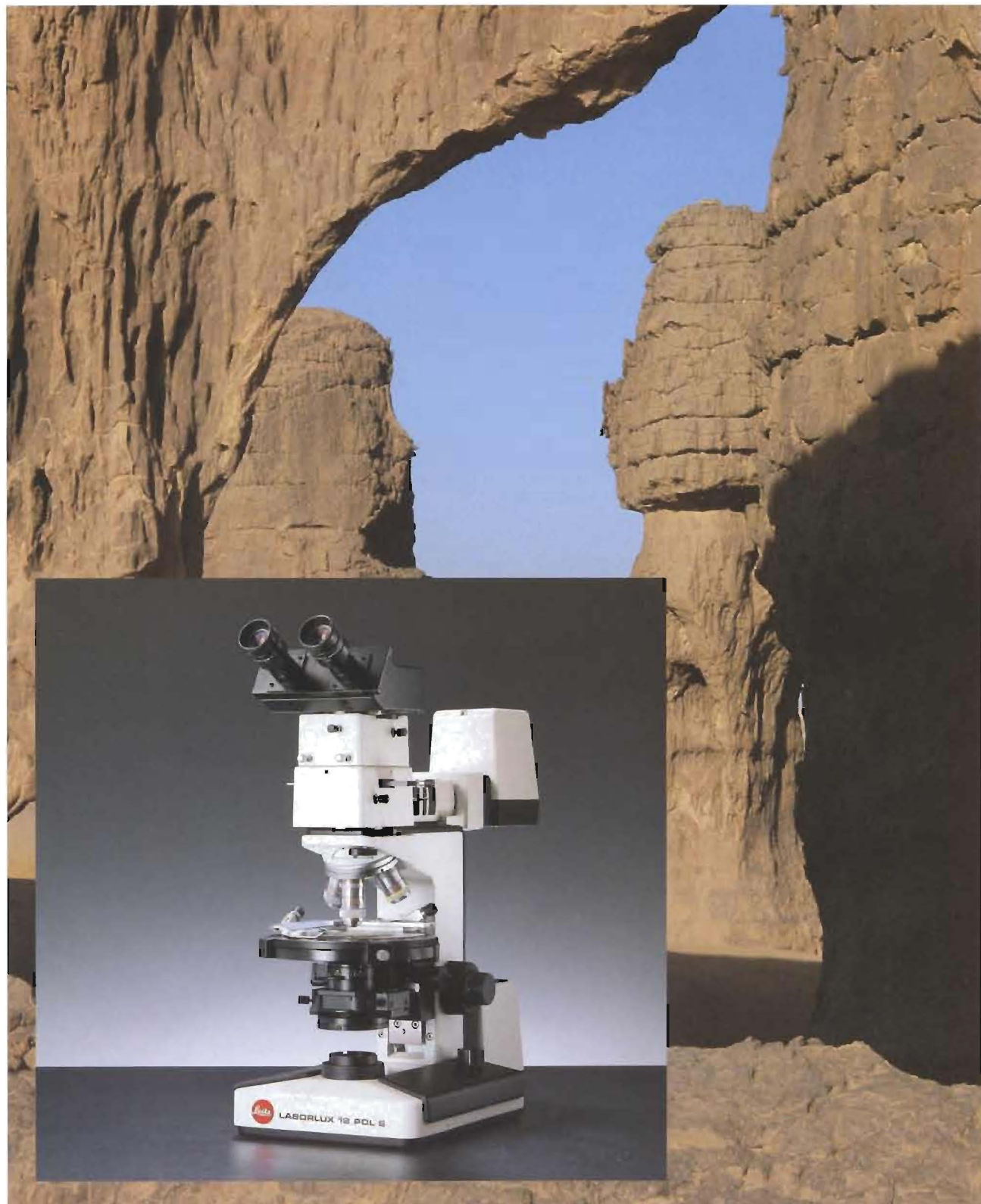

Vertical illuminators

The Pol vertical illuminators are fitted with a centerable aperture and field diaphragm. The integrated polariser can be disengaged, the analyser is rotatable through $\pm 8^\circ$. To avoid glare when the analyser is not in the light path, a compensating neutral density filter can be pushed into the empty hole of the analyser slide.

Pol vertical illuminator SR

This conventionally designed device has a semi-reflecting optical flat for full utilisation of the objective apertures and thereby has high resolving power. The vertical illuminator can easily be adapted for interference contrast by using appropriate modules and objectives with Wollaston prisms.

Pol vertical illuminator TR

This is particularly suitable for observation of specimens of low reflectivity and low anisotropic behaviour.

A totally reflecting optical flat serves as the deflecting element of the illuminating beam; like a Berek compensating prism it uses one half of the objective pupil for the illuminating beam while the other half is free for the observation beam.

In this illuminator, the built-in polariser is located beneath the optical flat instead of in front of it, which results in a better degree of polarisation.

Fluorescence observation is also possible by simply attaching a gas discharge lamp and inserting exciting and barrier filters.

SRB illuminator for incident and transmitted light

Illustrated on page 6. This illuminator is especially recommended for the observation of uncovered polished specimens or for frequent changes between incident and transmitted light.

All that is needed is a set of infinity objectives for incident / transmitted light (see table on page 13).

The illuminator consists of an optical flat which is removed for transmitted light, centerable Bertrand lens, pinhole stop for the conoscopy of small grains, analyser rotatable through $\pm 8^\circ$, push-in neutral density filter (optional), centerable aperture and field diaphragm, tube factor 1x for ∞ objectives.

Fluorescence illuminator

Fluorescence investigations can be carried out by fitting the microscope with the 3 Lambda PLOEMOPAK[®] ($\infty / 1x$) and a gas discharge lamp (preferably a 50 W ultra high-pressure mercury lamp).

Normal brightfield observations are also possible if the beam splitting system TU 45.55 with a neutral optical flat is used.

Fig. 5 Pol vertical illuminator SR



Fig. 6 Pol vertical illuminator TR



Eyepieces – objectives specimen stages – condensers

Eyepieces

The PERIPLAN® 10x/68 ⊕ eyepieces with 18 mm or 20 mm field of view are designed for spectacle wearers, although they can be just as easily used by viewers with normal eyesight. The roll-back eyecups then serve as protection from glare. Inserted in the normal position, the crosslines with a graduation of 10 mm = 50 divisions indicate the vibration directions of the polarisers. A second orientation on the eyepiece tube aligns the crosslines to indicate the vibrations of an object in a diagonal position. When calibrated, the crosslines can be used with an object micrometer for linear measurements.

Objective nosepiece

The quadruple nosepiece is centrable, so that each objective can be aligned to the axis of rotation of the stage. The objectives are therefore always centred, even after many changes of magnification. A precision internal clickstop mechanism keeps the centre of the image in place whenever the objective nosepiece is rotated.



Objectives

The excellent contrast rendering, high resolving power and superb field flattening of Leitz Pol objectives result in top-quality images ensuring fatigue-free viewing at all magnifications.

Pol objectives are characterised by their red engraving and the letter "P" denoting strainfree design. The magnification is easily identified by the use of different-coloured rings, and the outer casing is rotatable to facilitate reading of the lettering on the objective in the optical path.

To protect the specimen and the front lens at medium to top magnifications the front lens mounts are telescopically sprung.

Specimen stages

The stage of the LABORLUX 11 POL S is rotatable and permanently fixed. Its external diameter is 165 mm and the vertical stage travel is 25 mm. It has a 360° graduation and vernier reading of 1/10° for angle measurements.

The LABORLUX 12 POL S has an interchangeable stage with the same external diameter, so that large samples such as those encountered in soil science and industry can be examined without any problems. This stage is equipped with a 360° graduation with two verniers (1/10°) and a friction clamp for exact angle measurements.

The multi-format object guide accepts specimen slides of up to 50 x 50 mm and 26 mm x 76 mm and can be used on either stage. It has an adjustment range of 30 mm x 40 mm. The coordinates of set object points can be read on a millimetre scale with vernier to an accuracy of 0.1 mm. For systematic object scanning and for point counting methods, clickstop buttons can be supplied for distances of 0.1, 0.3, 0.4 and 1 mm.

Pol condensers

The condenser of the LABORLUX 11 POL S is fixed to the stage bracket. The integrated filter polariser can be rotated through 360°. The swing-out condenser top is interchangeable.

The PLK condenser on the LABORLUX 12 POL S is centerable and interchangeable. The condenser tops ensure homogeneous illumination for all objective apertures used.

Special condensers are available for phase contrast, darkfield and interference contrast.

*Fig. 7
LABORLUX 12 POL S, Pol tube S 20, intermediate tube 90B, strainfree objectives, removable stage, PLK Pol condenser.*



Universal Rotary Stage for Federow crystal studies

With the five-axis Universal Rotary Stage UT5, the second plane of symmetry can be set as soon as the first one has been found. This considerably simplifies and speeds up the measuring procedure.

A practical device for changing and clamping the sections also permits easy adjustment of the surfaces at the intersection points of the rotation and tilt axes.

For structure studies, the Schmidt object guide attachment allows parallel specimen displacement.

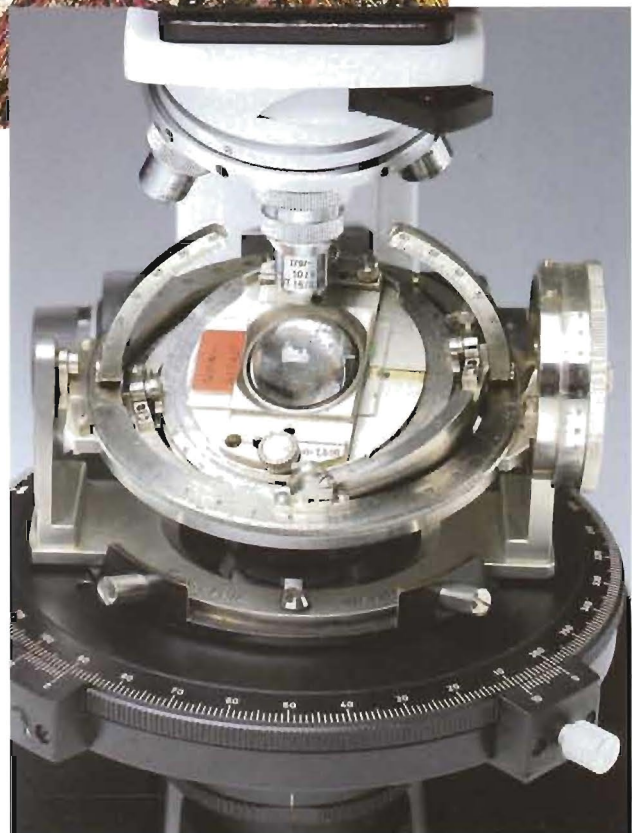

*Mica schist from Finland.
Photo: Dr. Jullmann, Justus Liebig-Universität Gießen.*

Fig. 8 Leitz UT 5 Universal Rotary Stage

A comprehensive range of compensators

Compensators

The wide range of compensators caters for all practical methods of determining vibration directions and the character of birefringence and measuring phase differences.

The compensators all have the DIN standard size of 20 mm x 6 mm. The inserted compensator is in the infinity light path of the tube lens system, so there is no risk of image displacement when the compensator is pushed in or out. The depth of the compensator slide is such that the compensator can remain in the tube slot when it is removed from the optical path, which makes it readily available.

Qualitative compensators

λ plate

The phase difference is about 550 nm and produces the interference colour first-order red.

$\lambda/4$ plate

Here the phase difference is about 137 nm, producing the colour first-order grey.

λ plate in subparallel position

Weak birefringence can be detected with this plate, because it reacts more sensitively to minor changes than a λ plate in the diagonal position. The plate can be rotated in its slide through a few degrees to find the best effect. This compensator arrangement is also suitable for observations with the Pol vertical illuminators SR and SRB.

Quartz wedge

The interference colours of the first to the fourth order are obtained when the wedge is adjusted in the tube slot.

$\lambda/4$ plate for circular polarisation

for the LABORLUX 12 POL S. When the $\lambda/4$ plate (32 mm diameter) is inserted in the condenser and the $\lambda/4$ compensator is in a crossed position in the tube slot, all birefringent objects appear in interference colours regardless of the position of the object.



*Plastic gear wheel, microtome section
Photo: Dr. W. Patzelt, Wetzlar.*

*Fig. 9
LABORLUX 12 POL S, intermediate tube 360 B, tilting compensator B,
multi-format object guide, Pol condenser PLK.*

Quantitative compensators

Tilting compensator B

with magnesium fluoride plate for about 5 orders.

Tilting compensator E

with double calcite plate for about twenty orders.
With the compensators B and E the phase difference is read from the sum of the two tilting angles straight from the table.

Tilting compensator K

with calcite plate for a measuring range of about thirty orders.
The phase difference is read from the sum of the calibrating constant and an angle-dependent value in a table.

$\lambda/4$ plate for Sénarmont measurements

The measurement range is 1 Lambda for the wavelength 546 nm.

The following items are required for such measurements:

- a) the rotatable analyser in the intermediate tube 360 B.
- b) monochromatic light e.g. with the aid of the interference filter 546 nm.

Rotary Brace-Koehler compensator

Measuring range up to 0.1 lambda for very small phase differences.



Synthetic fibre, photo: Dr. W. Patzelt, Wetzlar.



Accessories

Photomicrography

The Leitz ORTHOMAT® E and Wild MPS camera systems offer a choice of different camera attachments for all customary film formats from 24 mm x 36 mm up to 101.6 mm x 127 mm (4" x 5") and POLAROID® for instant documentation.

TV microscopy

Fast and easy assembly of TV cameras to show the microscope image to a large group of people, e. g. for teaching purposes.

Automatic microhardness testing

Non-destructive Vickers and Knoop hardness testing can be carried out by attaching the hardness tester. An accurate hardness imprint is obtained by automatic lowering of the indentation diamond. The objective is then turned into the light path and the imprint assessed and measured.

Heating stages

Leitz heating stages can be used for the observation of thermal reactions (e. g. determination of melting point, structural transformations) up to a temperature of 1350°C.

*Fig. 10
LABORLUX 12 POL S, intermediate tube 360 B, Pol phototube FSA 20
with WILD MPS 12 camera.*



Strainfree objectives for transmitted light microscopy

(use intermediate tube)

(for tube length 160 mm, parfocalising distance 45 mm)

Type of objective	Repr. ratio	Aperture	Free working distance in mm	Cover-glass correction ¹⁾
Strainfree plano objectives	PL 1,6*	0.05	7,20	-
	PL 2,5	0.08 P	11,80	-
Strainfree flatfield objectives EF P	EF 4	0.12 P	24,00	-
	EF 10	0.25 P	6,80	-
	EF 25	0.50 P	0,48	0,17
	EF 40	0.65 P	0,50	0,17
	EF 50	0.85 P	0,40	0,17
	EF 100	1.25 P OEL	0,10	0,17
Strainfree planachromats PL FLUOTAR* P	PL FLUOTAR 16	0.45 P	0,80	0,17
	PL FLUOTAR 25	0.55 P	0,51	0,17
	PL FLUOTAR 40	0.70 P	0,45	0,17
	PL FLUOTAR 100	1.32 P OEL	0,17	0,17

*) only strainfree under certain conditions (for orientating low-power observations).

1) - can be used with or without a coverglass
0.17 to be used with 0.17 mm coverglass.

Objectives for Universal Rotary Stages and for investigations with large working distances (with or without a coverglass)

(for tube length 160 mm, parfocalising distance = 45 mm, use intermediate tube)

Objective name scale / aperture for use with segment $n_D = 1.554$	Parfocalizing distance in mm	Free working distance in mm
UT 6.3 / 0.19	45	7,20
UT 16 / 0.34	45	2,27
UT 40 / 0.34	45	1,20
UT 32 / 0.50	45	1,00
UT 50 / 0.63	45	0,67
Scale / aperture for use without segment		
L 4 / 0.12 P	45	24,0
L 10 / 0.22 P	45	15,8
L 25 / 0.22 P	45	14,7
L 20 / 0.32 P	45	6,73
L 32 / 0.40 P	45	6,55

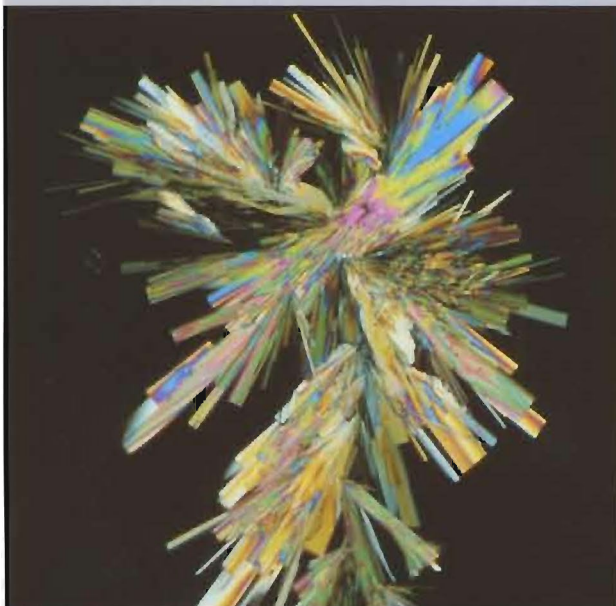

Melt specimen, photo: Dr. W. Patzelt, Wetzlar.

Strainfree objectives for transmitted and incident light microscopy

(to be used with SR, TR, SRB illuminators)

(for tube length ∞; parfocalising distance = 30 mm, for NPL 5 objective = 39 mm)

Type of objective	Repr. scale	Aperture	Free working distance in mm	Cover-glass correction ¹⁾
Achromats	20 x	0.30 P	4,80	-
	50 x	0.65 P	0,45	O
Planachromats	NPL 5 x	0.09 P**	6,20	-
	NPL FLUOTAR 10 x	0.22 P*	11,80	-
	NPL FLUOTAR 20 x	0.45 P*	2,31	O
	NPL FLUOTAR 50 x	0.85 P*	0,24	O
	NPL FLUOTAR 100 x	0.90 P*	0,10	-
Achromat	FLUOTAR 50 x	0.75 P	0,30	0,17
Immersion system	20 x	0.40 OEL P**	0,46	-
	32 x	0.65 OEL P	0,30	-
	50 x	0.85 OEL P	0,35	-
	125 x	1.30 OEL P	0,28	O

* can also be used for ICR interference contrast.

** not recommended for UV fluorescence excitation.

1) - = can be used with or without a coverglass.

O = use without a coverglass.

0.17 = use with a coverglass.

Eyepieces

Tube length 160 mm

PERIPLAN high-point	GF 10 x / field of view index 18 6∞ M
	GF 10 x / field of view index 18 6∞ ⊕
PERIPLAN high-point	GF 10 x / field of view index 20 6∞ M
	GF 10 x / field of view index 20 6∞ ⊕

The eyepieces marked with an M can be fitted with a graticule.
⊕ = Crosslines with horizontal scale for length measurements.

- 1 Straight tube 0 for photography.
- 2 Pair of PERIPLAN eyepieces 10x / 18 ϕ (\oplus crosslines).
- 3 Pair of PERIPLAN GF 10x / 20 ϕ \oplus eyepieces.
- 4 Pol tube P 42 / 30 (with Bertrand lens), not with SRB.
- 5 Pol tube S 20.
- 6 Pol tube R FSA 20 (R = back-reflection).
- 7 Leitz PLOEMOPAK for fluorescence investigations.
- 8 Intermediate tube 90, fixed swing-out analyser (90°) TL 160.
- 9 Intermediate tube 90 B (B = Bertrand lens), TL 160.
- 10 Intermediate tube 360 B (analyser rotatable through 360°), TL 160.
- 11 Pol vertical illuminator SR ∞ / 1x.
- 12 Heat-absorbing filter (required with the 100 W lamp).
- 13 Pol vertical illuminator TR ∞ / 1x.
- 14 Yellow-green filter, blue filter CB 16.5.
- 15 Pol illuminator for transmitted and incident light SRB (Bertrand lens), not for use with Pol tube P 42 / 30.
- 16 Incident light lamp holder with interior cable.
- 17 Lamphousing 20.
- 18 Filter.
- 19 Lamphousing 104.
- 20 Rotatable Brace-Koehler compensator.
- 21 Tilting compensators, B, E, K, measuring 5, 20, 30 λ .
- 22 Compensator with λ plate in subparallel position.
- 23 Compensator with $\lambda/4$ plate in subparallel position (Sénarmont), only with intermediate tube 360 B, measuring range 1 λ .
- 24 Quartz wedge 1st to 4th order.
- 25 λ compensator.
- 26 $\lambda/4$ compensator.
- 27 Dust protection slide.
- 28 Transmitted light Pol objectives: (EF, PL, PL FLUOTAR P and L / UT, tube length 160 mm).
- 29 Objective centring key.
- 30 ∞ objectives (achromats P, NPL FLUOTAR P).
- 31 Universal Rotary stage UT 5.
- 32 Pol object guide with pair of clickstop buttons 2.0 mm (0.1; 0.3; 0.4 and 1.0).
- 33 Pol rotary stage, interchangeable.
- 34 Pair of object clamps.
- 35 UT condenser UTK-A, 0.62.
- 36 UT condenser UT-A, 0.40.
- 37 UT condenser holder.
- 38 Condenser top ACHR 0.90 S 1.1 P.
- 39 Condenser bottom.
- 40 Condenser holder.
- 41 $\lambda/4$ plate for circular polarisation.
- 42 Regulating transformer for the 12 V 100 W lamp.
- 43 Mains connecting cable with earthed plug.
- 44 Condenser top As 0.90 P.

Leitz LABORLUX 11 POL S with non-interchangeable specimen stage, fixed condenser bottom, interchangeable condenser top and built-in 6 V / 10 W transmitted light illuminator.

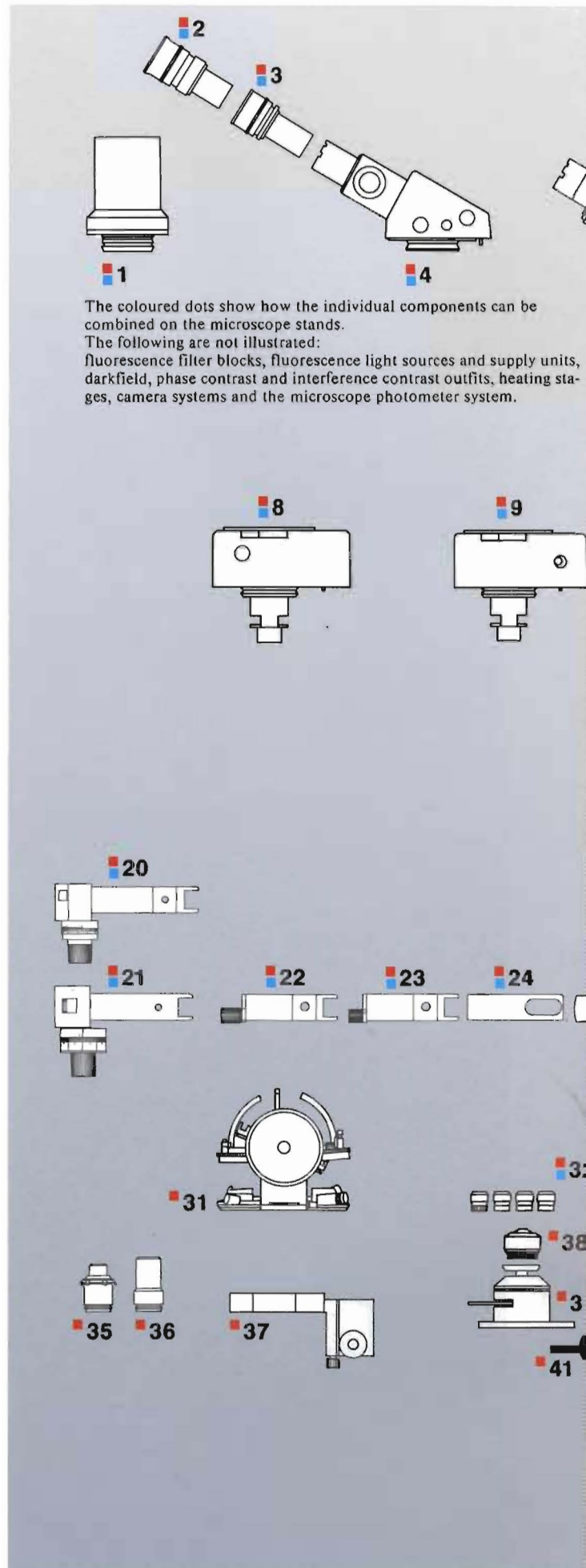
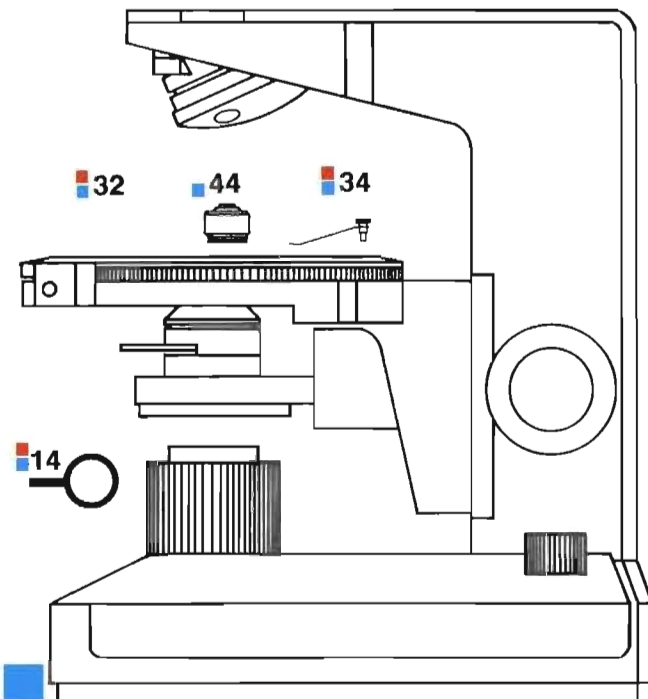

The coloured dots show how the individual components can be combined on the microscope stands. The following are not illustrated: fluorescence filter blocks, fluorescence light sources and supply units, darkfield, phase contrast and interference contrast outfits, heating stages, camera systems and the microscope photometer system.

The whole system at a glance

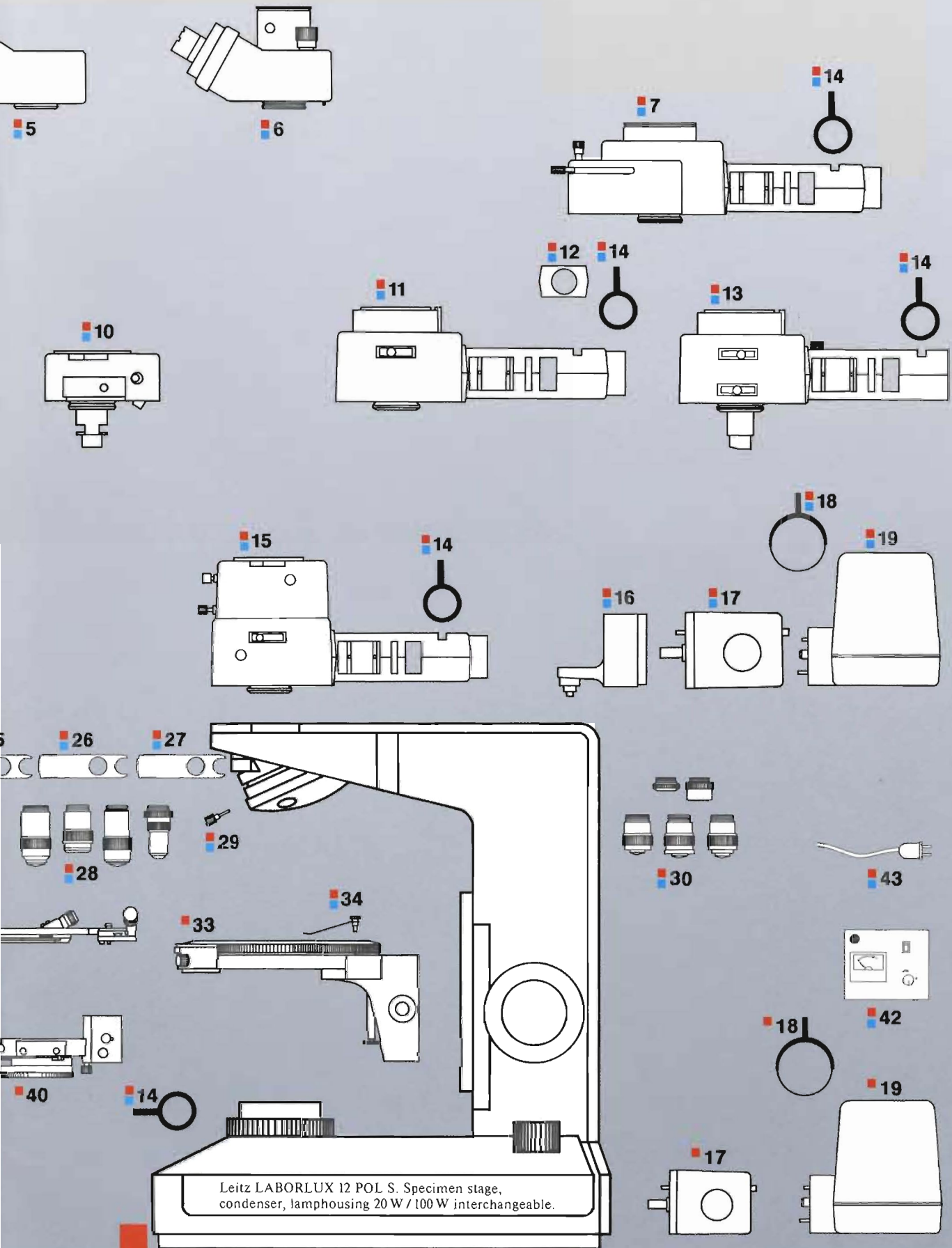

Leica

**Leica Mikroskopie
und Systeme GmbH**

Ernst-Leitz-Straße
P. O. Box 20 40

D-6330 Wetzlar 1

Tel.: (0 64 41) 29-0

Telefax: (0 64 41) 29-3399

Telex: 4 83 849 leiz d

Order Nos. of the editions in:
English German French
913 497 913 496 913 498

* = registered trademark
Design and specifications subject to alteration
without notice.

Part No. 550-063 engl.

Printed in Germany
X1/90/GX/B.