

82214

DESCRIPTIVE CATALOGUE
OF
OPTICAL INSTRUMENTS
AND
APPARATUS

CONSTRUCTED AND SOLD BY
WATKINS AND HILL,
5 CHARING CROSS, LONDON.

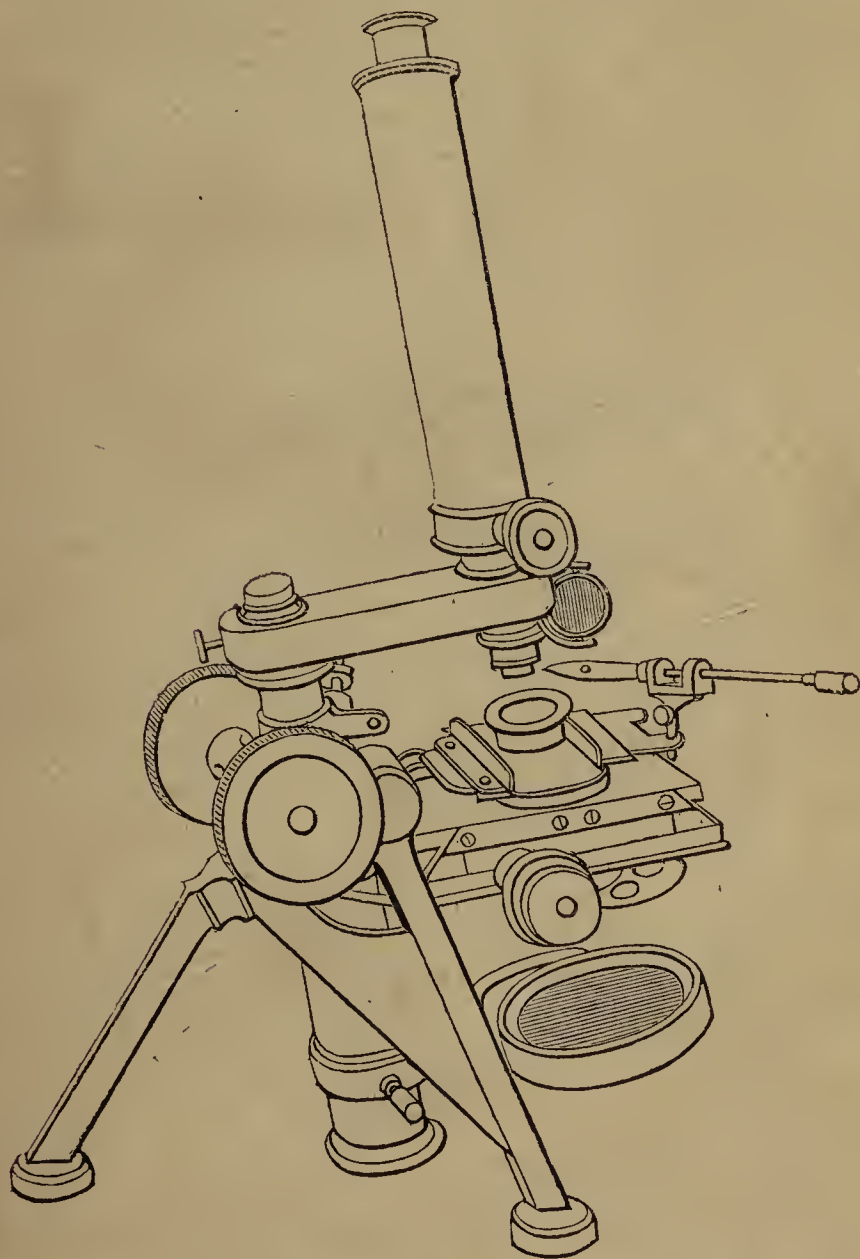

Illustrated by 178 Engravings.

Price Sixpence.

20 411-808

WELLCOME INSTITUTE LIBRARY	
Coll.	welMOmec
Call	pa m
No.	WW 350
	186*
	W33d



22400004002

DESCRIPTIVE CATALOGUE
OF
OPTICAL INSTRUMENTS
AND
APPARATUS

CONSTRUCTED AND SOLD BY

WATKINS AND HILL,
5 CHARING CROSS, LONDON.

Under this head are classed not only those Instruments employed for the improvement of Sight, and the examination and measurement of those objects and appearances, which, from their size or distance, would otherwise elude observation, but also those Instruments and Apparatus that are best adapted for the illustration of the properties of Light; such, for instance, as regulate its direction, intensity, state of polarization, colours, and interference of its rays.

SPECTACLES.

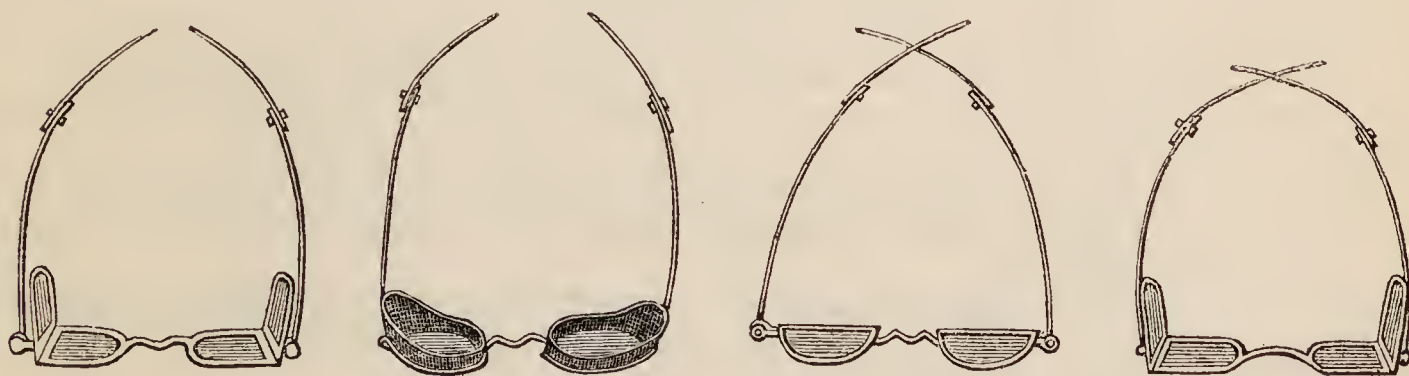

1. Best double-side Gold Spectacles with glasses, £2 12s. 6d. to £4 14s. 6d.
2. Best single-side Gold Spectacles with glasses, £2 2s. to £4 4s.
3. Best double-side Gold Spectacles with Brazil pebbles, £3 3s. to £5 5s.
4. Best single-side Gold Spectacles with Brazil pebbles, £2 12s. 6d. to £4 14s. 6d.
5. Best double-side Silver Spectacles with glasses, £1 1s.
6. Best single-side Silver Spectacles with glasses, 13s.
7. Best double-side Silver Spectacles with Brazil pebbles, £1 10s.
8. Best single-side Silver Spectacles with Brazil pebbles, £1 2s.
9. Double-side light-blued Steel Spectacles with best Brazil pebbles, 18s. to £1 5s.
10. Single-side light-blued Steel Spectacles with best Brazil pebbles, 15s. to £1 1s.
11. Best double-side light-blued Steel Spectacles with glasses, 16s.
12. Best single-side light-blued Steel Spectacles with glasses, 12s.
13. Double-jointed Tortoiseshell Spectacles with Brazil pebbles, £1 5s.
14. Single-jointed Tortoiseshell Spectacles with Brazil pebbles, 18s.

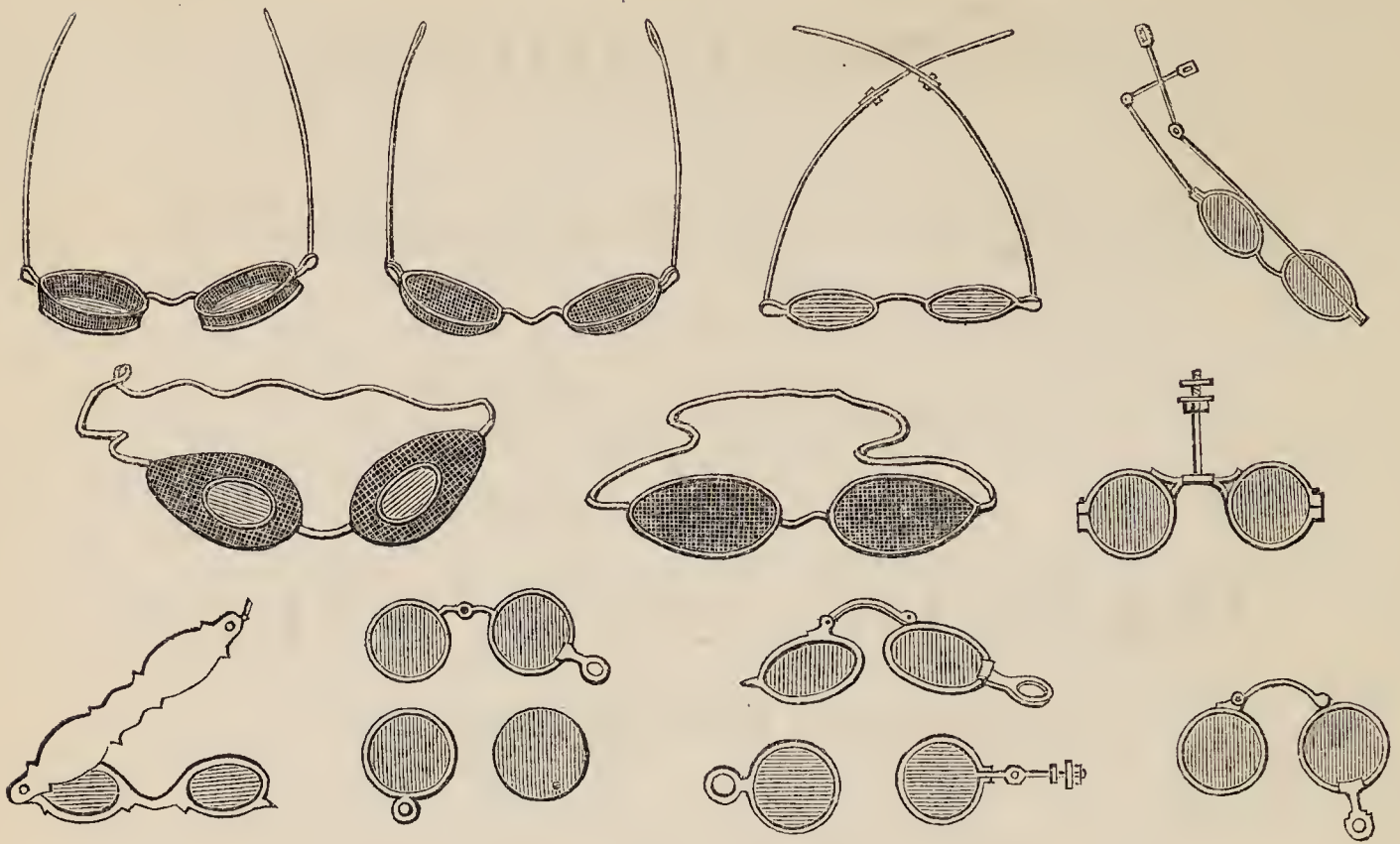

15. Double-jointed Tortoiseshell Spectacles with glasses, 16s.
16. Single-jointed Tortoiseshell Spectacles with glasses, 10s.
17. Double-sided Steel Spectacles of a commoner kind with glasses, 4s. 6d., 8s. 6d. and 12s. 6d.
18. Single-sided Steel Spectacles of a commoner kind with glasses, 3s. 6d., 6s. 6d., and 9s.
19. Half-eyed Spectacles made in steel, silver or gold, adapted for giving uninterrupted vision either above or below the glasses according to the nature of the sight. The same price as the ordinary-shaped frames.
20. Double-jointed Tortoiseshell and Silver Spectacles with folding side glasses, crape or wire-gauze for defending the eyes from sun, wind or dust, £1 11s. 6d.
21. Double-jointed blued Steel Spectacles with folding side glasses, crape or wire-gauze for defending the eyes from sun, wind or dust, £1 5s.
22. Single-jointed blued Steel Spectacles with folding side glasses, crape, or wire-gauze for defending the eyes from sun, wind or dust, £1 1s.
23. Wire-gauze Goggles with neutral tint glass centres, for protecting the eyes from sun, wind or dust, mounted in double- or single-jointed blued steel frame, 16s. and £1 1s.
24. Wire-gauze Goggles without glasses, for protecting the eyes from sun, wind or dust, mounted in double- or single-jointed blued steel frames, 14s. and 18s.
25. Wire-gauze Goggles with an India-rubber band for passing round the head, 5s. 6d.
26. Wire-gauze Goggles with neutral tint glass centres, and an India-rubber band for passing round the head, 6s. 6d.
27. Single- or double-jointed blued Steel Spectacles with blue, green or neutral tint glasses, for protecting weak eyes from the effect of the glare of lamps or candles, 12s. and 16s.
28. Spectacles with glasses adapted for eyes that have been couched.
29. Goggles to correct the habit of squinting.
30. Spectacle cases of various kinds, Tortoiseshell, Scotch, Papier Maché, Leather, &c., 6d. to £1 1s.
31. Gold and Pearl folding hand Spectacles, £3 13s. 6d. to £6 6s.
32. Gold and Tortoiseshell folding hand Spectacles, £3 13s. 6d. to £5 15s. 6d.
33. Silver and Pearl folding hand Spectacles, £1 16s. to £2 12s. 6d.
34. Silver and Tortoiseshell folding hand Spectacles, £1 11s. 6d. to £2 12s. 6d.
35. Gold double Eye-glasses, £2 2s., £2 12s. 6d., £4 4s. and £5 5s.
36. Gold double Eye-glasses to open with a spring, £2 12s. 6d., £3 3s. and £5 5s.
37. Gold double Eye-glasses with spring bridge for holding on the nose, £2 12s. 6d. and £3 3s.
38. Silver double Eye-glasses, 16s. to £1 1s.
39. Tortoiseshell double Eye-glasses with gold or steel spring bridge for holding on the nose, 16s. to £1 5s.
40. Tortoiseshell double Eye-glasses with best Brazil pebbles, £1 1s.
41. Tortoiseshell double Eye-glasses with glasses, 8s. 6d. and 12s.

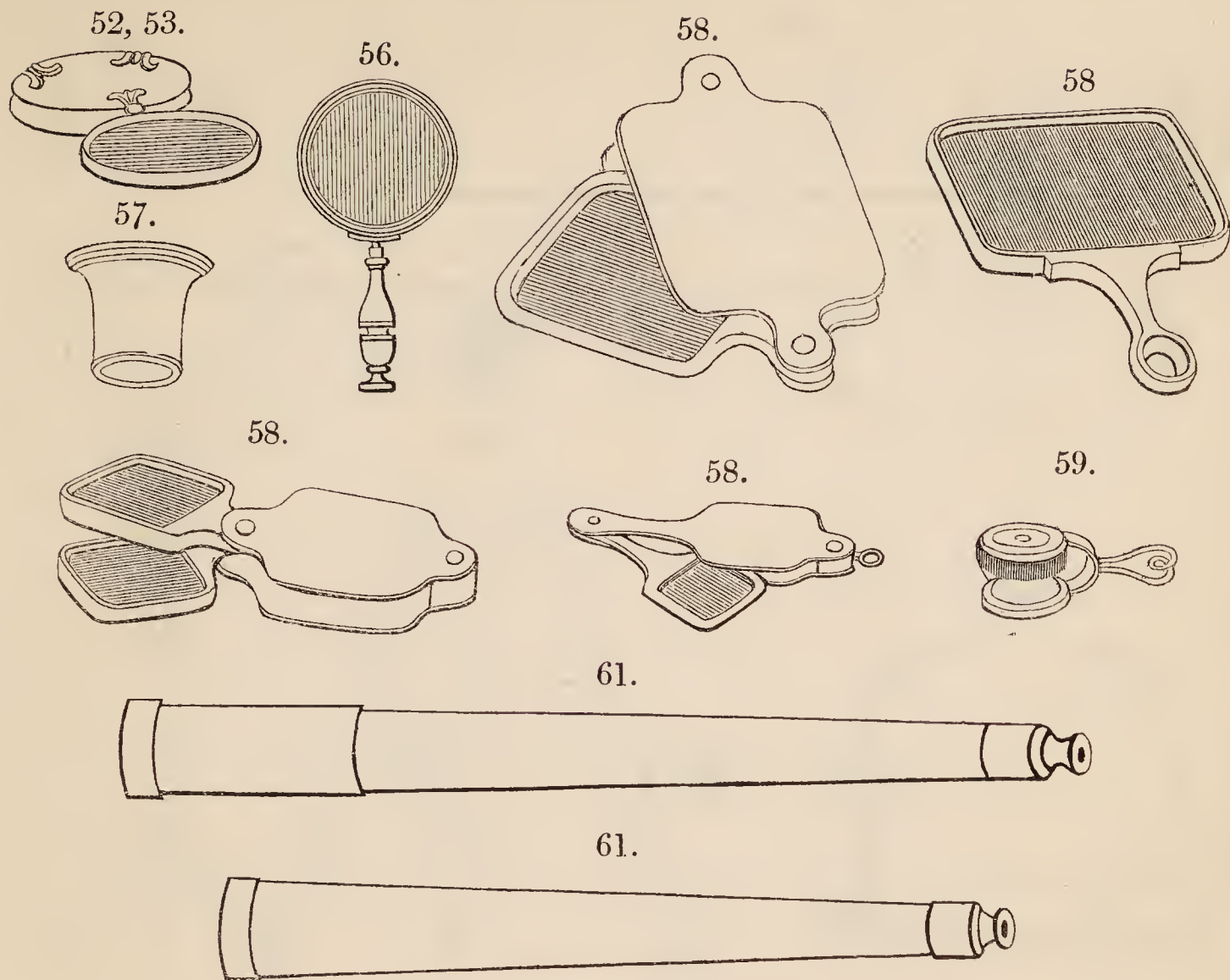

- 42. Gold single Eye-glasses, 10s., 12s., 15s., £1 1s., £1 5s. to £1 16s.
- 43. Gold single Eye-glasses in pearl cases, £2 2s. and £2 12s. 6d.
- 44. Gold single Eye-glasses in tortoiseshell cases, £1 10s. to £2 2s.
- 45. Silver single Eye-glasses, 5s. 6d. to 12s.
- 46. Silver and Pearl single Eye-glasses, 12s. to £1 1s.
- 47. Silver and Tortoiseshell single Eye-glasses, 10s. to £1 1s.
- 48. Gilt single Eye-glasses, 5s. to 15s.
- 49. Tortoiseshell single Eye-glasses, 4s. and 4s. 6d.
- 50. Horn single Eye-glasses, 2s. 6d.
- 51. Horn double Eye-glasses, 5s. 6d. to 9s.
- 52. Reading-glasses in silver and pearl mountings, 18s. to £2 12s. 6d.
- 53. Reading-glasses in silver and tortoiseshell mountings, 18s. to £2 12s. 6d.
- 54. Reading- or Map-glasses in tortoiseshell mountings, 10s. to £1 1s.
- 55. Reading- or Map-glasses in horn, 2s. 6d. to 7s.
- 56. Reading- or Map-glasses in ivory or wood circular frames with handles, 7s. 6d. to £1 1s.
- 57. Convex Lenses, mounted in horn or wood for Watchmakers, Engravers, &c., 1s. 6d. to 2s. 6d.
- 58. Magnifying Lenses with the glasses ground in a cylindrical form, of great power, and without spherical aberration, mounted in horn frames, 10s. 6d., 14s. 6d., 18s., £1 1s., £1 5s., £1 11s. 6d. and £1 16s.
- 59. Spectacle cleaners mounted in silver or German silver, and fitted either with leather cushions or small circular brushes, very useful for removing dust, &c. from the glasses of spectacles without scratching, 3s. to 10s. 6d.

TELESCOPES.

- 60. Naval Telescopes with long mahogany tube, a brass sliding eye-drawer and an achromatic object- or field-glass, from 1 foot to 8 feet long ; at per foot £1 1s.

64.



68.



66.



68.



69.

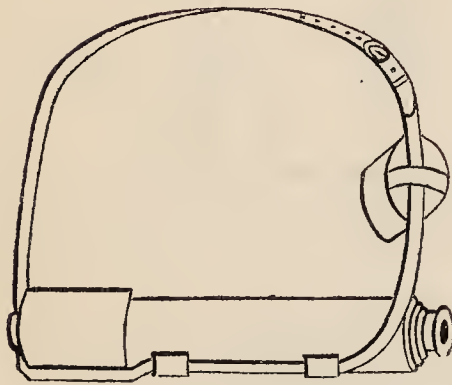

72.

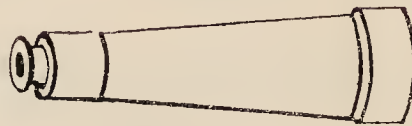

74.

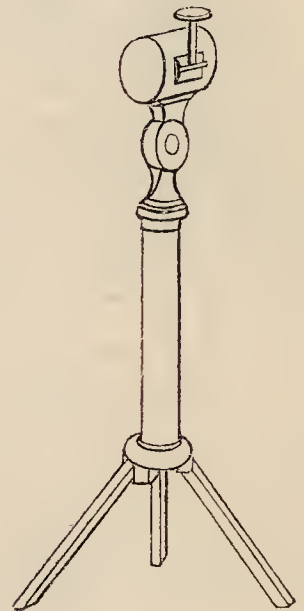

61. Naval Telescopes with object-glasses of larger apertures :—

1 foot long . . . £1 11s. 6d.

1½ foot long .. £2 2s.

2 feet long . . . £2 12s. 6d.

30 inches long . . . £3 13s. 6d.

3 feet long £5 5s.

4 feet long £8 8s.

62. Naval Telescopes mounted in German silver :—

1½ foot long . . £2 12s. 6d.

2 feet . . £3 3s.

30 inches . . £4 4s.

63. Night Telescopes with achromatic object-glasses, to be used at sea, in mahogany tubes mounted with brass, 2 feet long, £3 3s.

64. Achromatic Telescopes, to be used at sea in the night, which are generally preferred to those of the old construction, on account of the object being shown erect, £4 4s.

65. Achromatic Telescopes calculated to use by day or night, £3 3s.

66. Day or night Naval Telescope with brass body covered with leather, and sliding tube for protecting the object-glass from the rays of the sun, rain or spray, £4 14s. 6d.

67. Achromatic Telescope for hazy weather, £4 4s.

68. Improved Pocket or Portable Military Telescopes with brass sliding tubes :—

1 foot long when drawn out, and	3 inches when shut up,	£1 8s.
1 foot	5 inches	£1 16s.
1½ foot	7 inches	£2 12s. 6d.
2 feet	9 inches	£3 13s. 6d.
2½ feet	10 inches	£4 14s. 6d.
3 feet	11 inches	£5 15s. 6d.
4 feet	14 inches	£8 18s. 6d.

* * * The above-sized Telescopes made even more portable at Half-a-Guinea extra.

69. Improved Portable or Military Telescopes with brass bodies, covered with black or brown leather, and leather caps with a sling strap, answering the purpose of a case without the additional bulk, 1½ foot, £3 3s.; 2 feet, £4 4s.; 2½ feet, £5 5s.; 3 feet, £6 6s.

70. The above Telescopes, with the addition of a sliding tube for protecting the object-glass from the rays of the sun, rain or spray, extra 10s. 6d. If with a magnetic compass fitted in the cap, from 16s. to £1 1s. extra.

77.

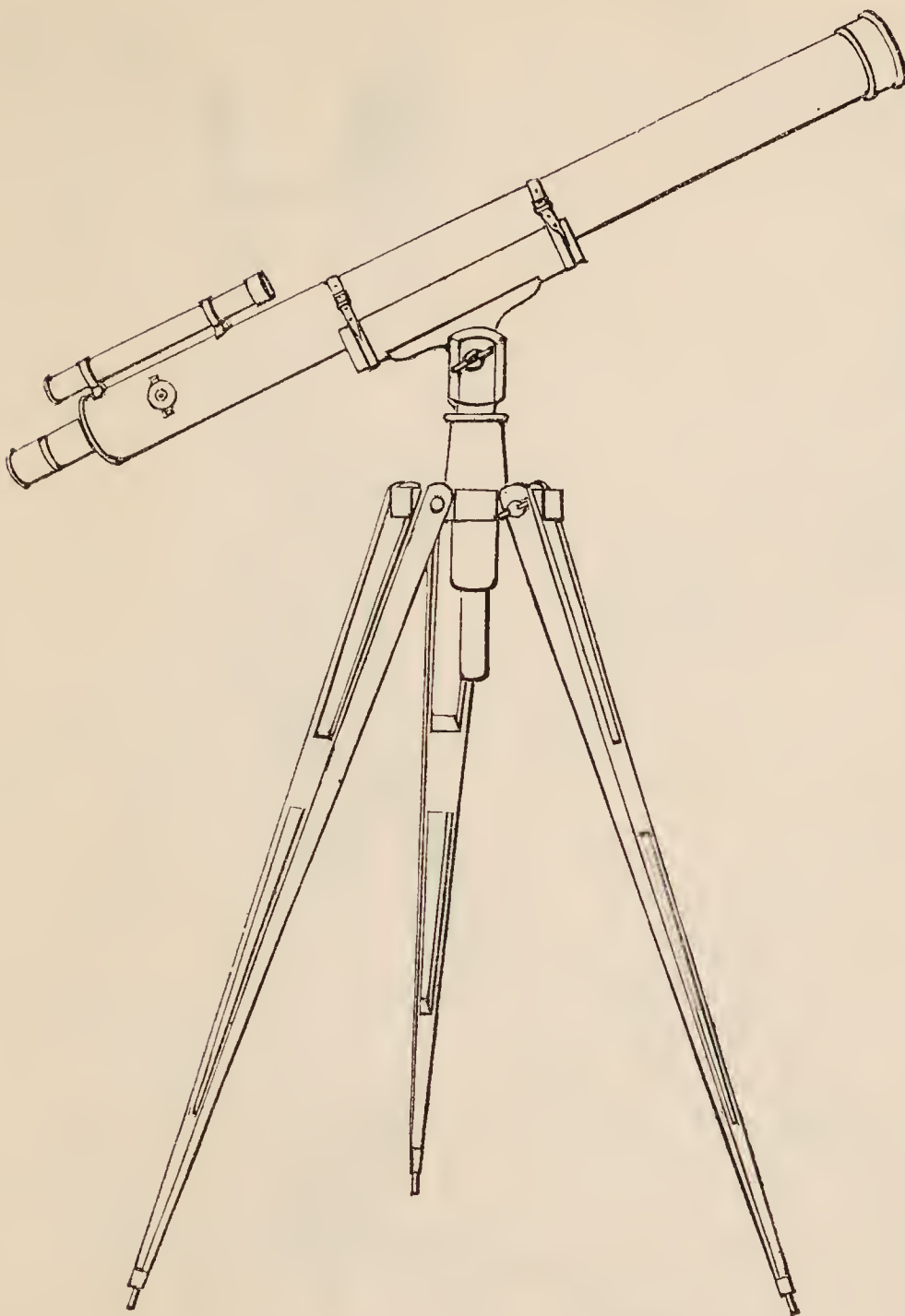

75.



76.



78.

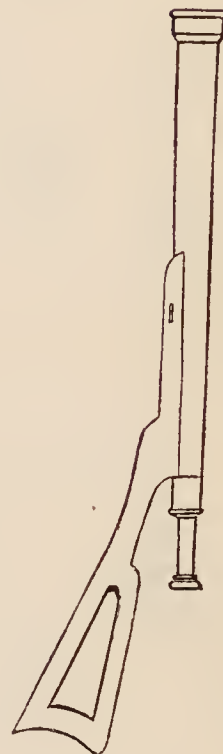

71. Portable or Military Telescopes, mounted in German silver :—
 1 ft. pocket telescope .. £2 5s. 1½ ft. portable telescope.. £3 3s.
 1 ft. portable ditto £2 12s. 6d. 2 ft. portable ditto £4 4s.
72. Improved Portable Telescope with one drawer of extra high power, £2 12s. 6d.
 73. Telescopes fitted up as Walking Sticks, £2 12s. 6d. to £3 13s. 6d.
 74. Brass Clips with portable pillar and claw stands to support the pocket telescopes more steadily than they can be by the hand, £1 1s. to £3 3s.
 75. Clips with screws, partially serving the purpose of a stand for the pocket telescopes; very portable, £1 1s. to £2 12s. 6d.
 76. Improved Portable Clips for carrying in the waistcoat pocket, by which a telescope may be fixed firmly in any position, £1 5s.
 77. Large Portable Mahogany or Walnut Stand, with vertical and horizontal motions, fixed by clamping screws, and adapted for supporting large telescopes of any size, £3 5s.
 78. Telescope support, constructed on the principle of a gun stock, very useful when it is required to steady a telescope for some minutes, and where there are none of the ordinary means of support, £1 1s.
 79. Leather cases with sling straps for the portable telescopes, 1½ foot, 6s. 6d.; 2 feet, 7s. 6d.; 2½ feet, 8s. 6d.; 3 feet, 9s. 6d.; and 4 feet, 10s. 6d.
 80. Achromatic Telescopes 2 feet long, with brass tube, on plain pillar and claw stand, one eyepiece for terrestrial and one for celestial observations, varying the magnifying power, packed in neat mahogany case, £8 8s.

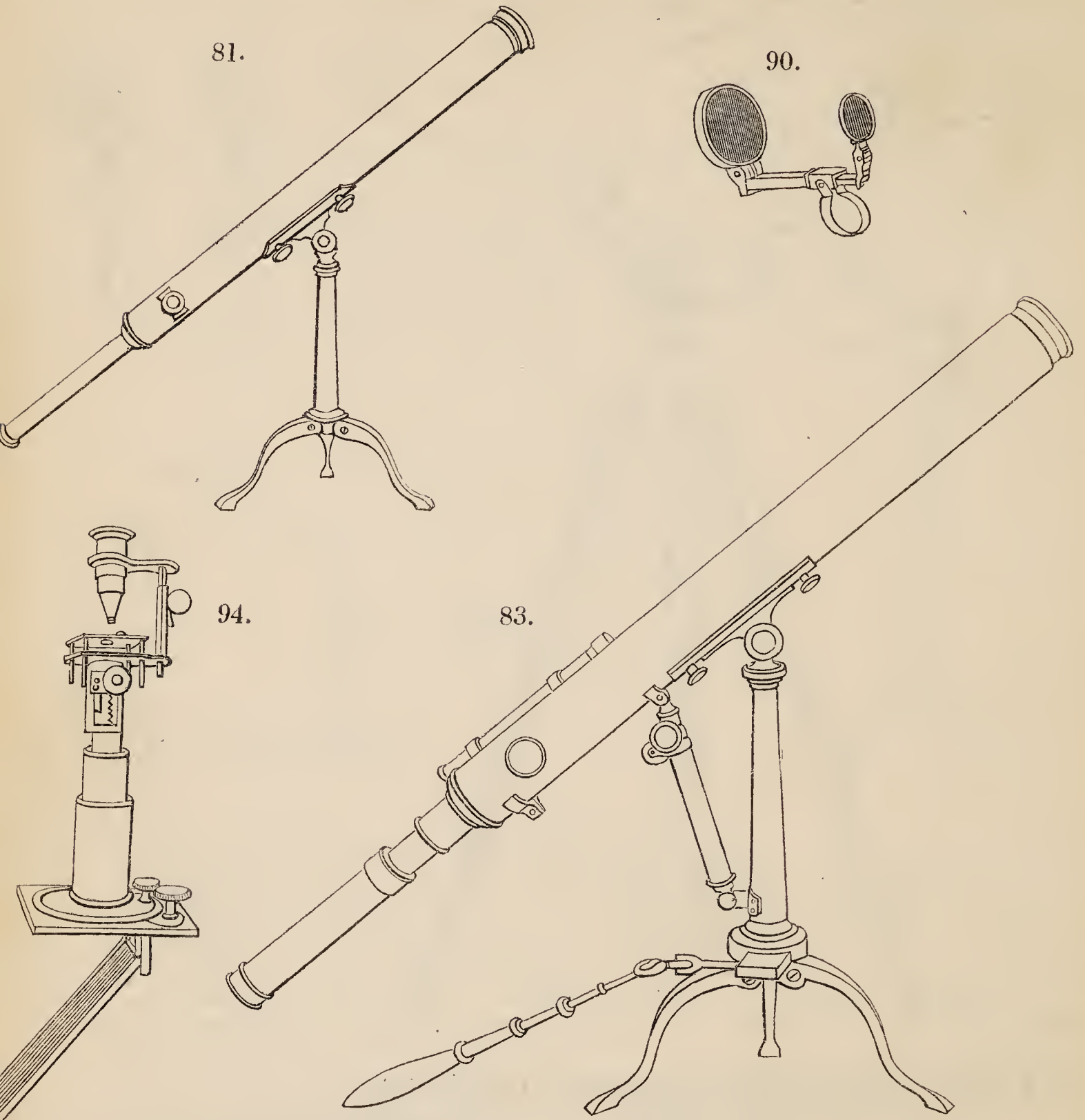

81. Achromatic Telescope $2\frac{1}{2}$ feet long, with brass tube on plain pillar and claw stand, two eye-pieces for terrestrial and one for celestial observations, to vary the magnifying power, packed in neat mahogany case, £10 10s., £12 12s. and £14 14s.
82. Achromatic Telescope $3\frac{1}{2}$ feet long, $2\frac{3}{4}$ inches aperture, with brass tube on plain pillar and claw stand, two eye-pieces for terrestrial and two for celestial observations, the celestial eye-pieces magnifying up to 150 times; packed in neat mahogany case, £21.
83. Achromatic Telescope $3\frac{1}{2}$ feet long, $2\frac{3}{4}$ inches aperture, with vertical and horizontal rack and pinion motions, achromatic finder, two terrestrial and three celestial eye-pieces, those for celestial observations magnifying up to 200 times; packed in a strong mahogany case, £26 5s.
84. Achromatic Telescope 4 feet long, $3\frac{1}{4}$ inches aperture, with brass tube on plain pillar and claw stand, with sliding steadying rods, and 4 eye-pieces to vary the magnifying power; packed in a strong mahogany case, £35.
85. Achromatic Telescope $3\frac{1}{2}$ feet long, $3\frac{1}{4}$ inches aperture, with vertical and horizontal rack-work motions, achromatic finder, two terrestrial and three celestial eye-pieces, magnifying up to 250 times; packed in a strong mahogany case, £40.
86. Achromatic Telescope $3\frac{1}{2}$ feet long, $3\frac{3}{4}$ inches aperture, on an universal equatorial stand in place of the simple pillar and claw stand, £70.

* * Telescopes of larger dimensions constructed to order.

92.

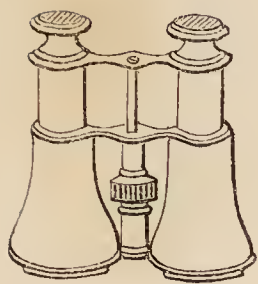

89.



87, 88.

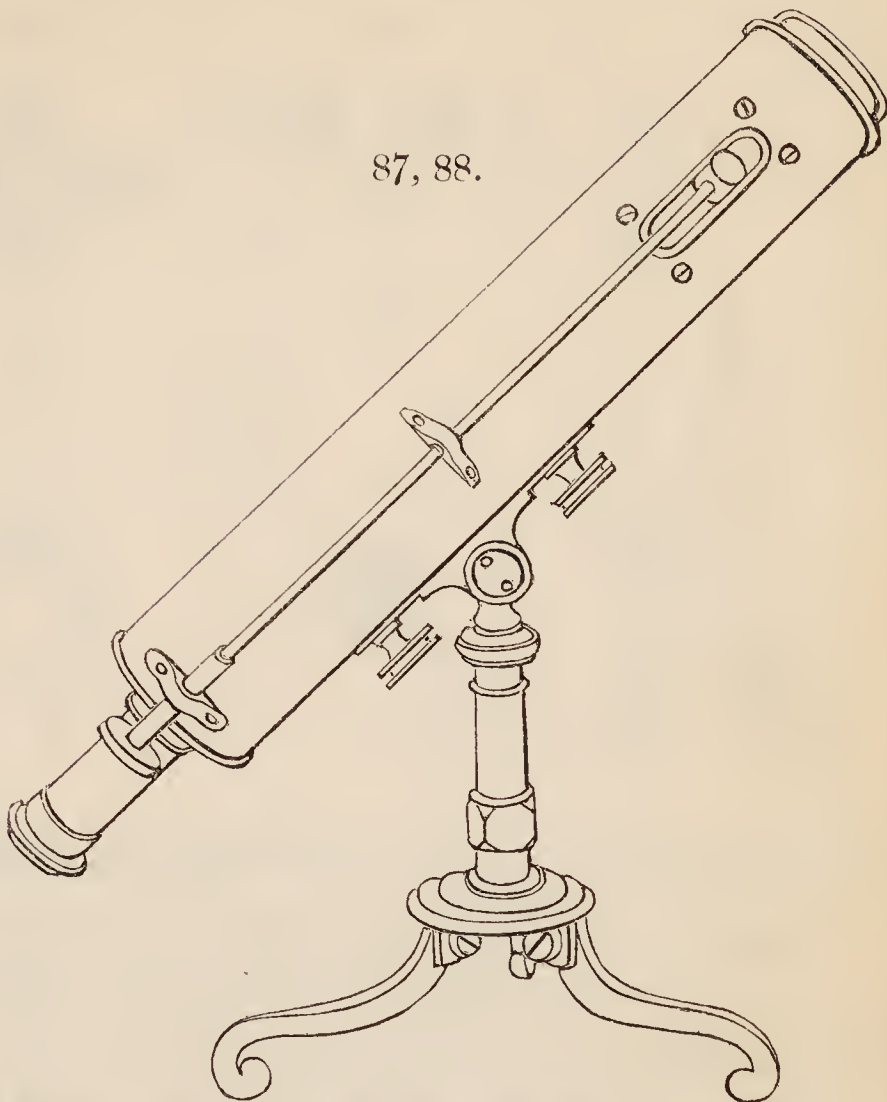

96.

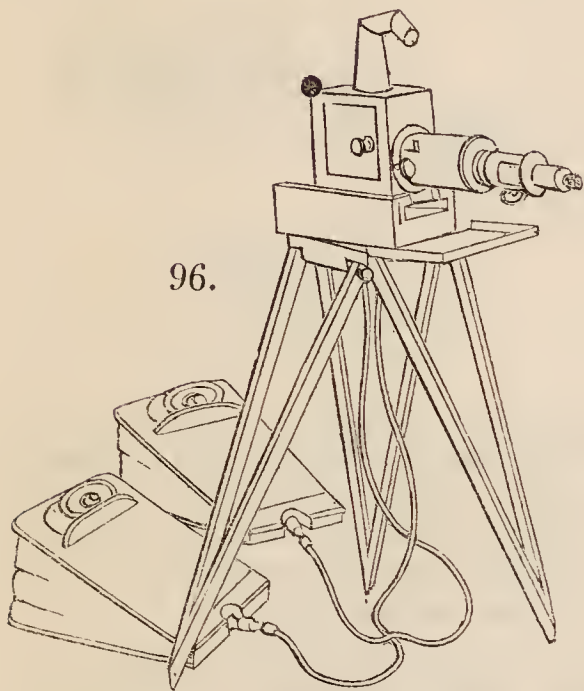

87. Gregorian Reflecting Telescopes with brass tubes, on pillar and claw stands, packed in mahogany cases:—

1 foot. . £6 6s.

1½ foot. . £9 9s.

2 feet. . £14 14s.

Two feet, with speculum 4 inches diameter and rackwork motions, £26 5s.

Three feet, 5 inches diameter and rackwork motions, £44.

88. Dumpy Gregorian Reflecting Telescopes on plain pillar and claw stands, packed in mahogany cases:—

Brass tube 7 inches long and speculum 2 inches diameter, £12 12s.

Brass tube 8 inches long with finder and speculum 3 inches diameter, £23.

Brass tube 12 inches long and speculum 3 inches diameter, £18 18s.

Brass tube 15 inches long with finder and speculum 4 inches diameter, £33 12s.

Brass tube 24 inches long with finder and improved rackwork movement to stand, speculum 5 inches diameter, £50.

89. Single Opera Glasses of all sizes, mounted in ivory, tortoiseshell, horn, papier maché, and japanned metal, with silver-plated or gilt drawers, from 10s. 6d. to £3 3s.

90. Portable single Opera Glasses or Perspectives for carrying in the waistcoat pocket, mounted in silver, £1 11s. 6d. to £2 12s. 6d.

91. Large Binocular Glasses of higher magnifying power than the ordinary opera glasses, for using at sea for military purposes, deer stalking, the race course, &c., with shades covered with leather, or in a leather case with sling, £4 14s. 6d. to £7 17s. 6d.

92. Double Opera Glasses of all sizes and patterns, mounted in ivory, tortoiseshell, buffalo-horn, papier maché, and japanned metal with silver-plated or gilt drawers and mountings, £2 2s. to £10 10s.

93. Diagonal Opera Glass. The peculiar artifice of this arrangement enables a person to see objects at a short distance, either to the right or left, above or below, while he is apparently looking straightforward, £1 1s. to £2 2s.

MICROSCOPES.

94. Solar Microscope. By the aid of solar light, this instrument exhibits to a number of observers at the same time, highly magnified images of very minute, opaque and transparent objects thrown upon a flat wall or screen, £6 6s. to £21.

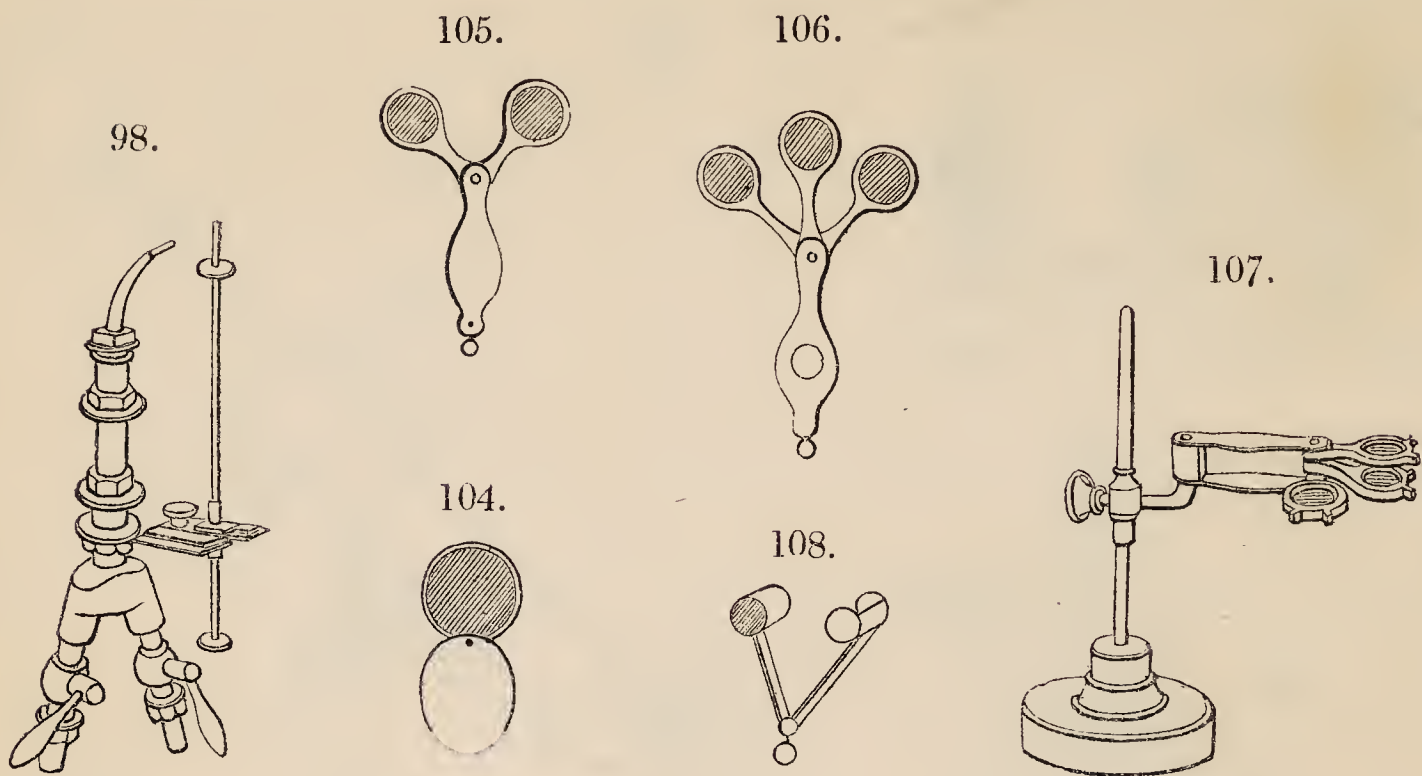

95. **Oxyhydrogen Microscope.** The advantage of this instrument consists in its independence of the sun for the display of its power, as the light produced by the combustion of oxygen and hydrogen gases upon lime is so intense, that objects are made visible on a screen nearly equal to that effected by a solar microscope under the most favourable circumstances; therefore the instrument is admirably adapted for microscopic illustration at all times in the lecture-room, for private instruction and amusement.
Microscope with 3-inch condensing lenses, 1 low power and 2 high powers, japanned tin body, sliding brass tubes for adjustment of the focus, mahogany lantern with japanned tin cover, set of objects prepared with Canada balsam; the whole packed in a case complete, £8 8s.
The above Microscope without objects, case and lantern, £5 5s.
Microscope with 3¼-inch condensing lenses, 1 low power and 2 double high powers, brass body, adjustment to the condensers, rack and pinion motion for regulating the focus, mahogany lantern with japanned tin cover, objects prepared in Canada balsam, water troughs for animalculæ, &c.; the whole packed in a case complete, £15 15s.
The above Microscope without objects, case and lantern, £8 8s.
96. Oxyhydrogen Microscopes of larger sizes mounted on high mahogany stands, from £21 to £30.
97. Oxyhydrogen Lime-Light Apparatus to suit the Microscope, consisting of large caoutchouc cloth gas-bags, strongly hinged pressure boards, India rubber flexible tubes, each 10 feet long, furnished with brass coupling or union joints, oxyhydrogen blowpipe and lime holder; leaden retort and glass purifier, fitted with flexible metallic pipes for generating hydrogen gas; iron retort and metallic pipes for preparing oxygen gas, £14 14s. to £21. If the blowpipe is supplied with a clockwork motion for rendering the revolution of the lime cylinder constant during combustion, extra £5 5s.
98. Oxyhydrogen Blowpipe and Lime Holder; may be used either in a lantern for the purposes of illuminating the Microscope or Polariscope, or when mounted on a massive iron foot with a joint for various other experiments connected with the demonstration of the properties of light, £2 12s. 6d. and £3 3s.
99. Prepared Lime Cylinders for the oxyhydrogen light, in closed air-tight bottles, per dozen 3s. 6d. and 5s. 6d.
100. Objects for the Gas Microscope, prepared in Canada balsam and mounted in mahogany frames, in great variety, 2s. to 5s.
101. Glass Water Troughs for showing animalculæ, and also for exhibiting the decomposition of water, 3s. to 7s. 6d.
102. Apparatus for illustrating in the Gas Microscope the formation of the magnetic curves, by dropping iron filings about the poles of a small horseshoe magnet, 5s. 6d. to 8s. 6d.
103. **Lucernal Microscope.** The peculiar advantage of this microscope consists in its displaying every variety of opaque and transparent objects, under a brilliant and magnifying appearance, on a ground glass screen, and that the outlines of those objects may be taken even by persons not much accustomed to drawing, £15 15s. to £25.

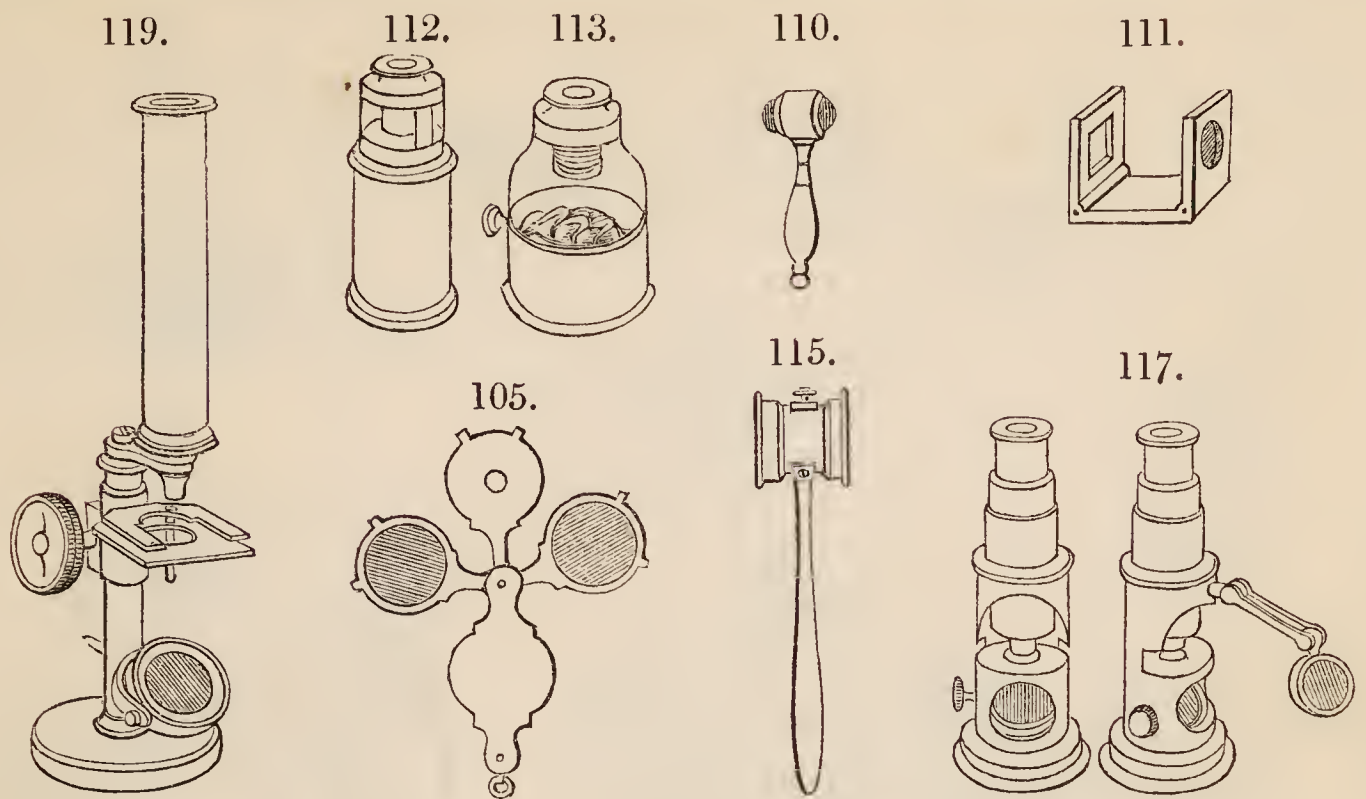

104. Single Magnifying Lenses convenient for pocket microscope, in various kinds of mountings, 2s. 6d. to 7s. 6d.
105. Two Magnifying Lenses mounted in horn or tortoiseshell; these can be combined or used separately, and thus form three degrees of magnifying power, 5s. to 9s.
106. Set of Three Magnifying Lenses mounted in a tortoiseshell or horn case, of a convenient size for the waistcoat pocket. This useful optical combination affords many degrees of magnifying power by varying the arrangement of the lenses, or by taking each separately, 6s. 6d. to 15s.
107. Small Brass Stand on which the above lenses may be fixed, 2s.
108. Coddington Lens. This lens is of very high magnifying power, and is found extremely useful for opaque objects; for being spherical, the curvature of the image is very considerably diminished; mounted in ivory, horn, tortoiseshell, German silver or silver, 5s. to £1 1s.
109. Coddington and Stanhope Lenses mounted together in a convenient pocket form for viewing minute specimens. The advantage of this combination, suggested by Mr. Brooke, consists in the Stanhope lens serving as an achromatic condenser, 18s.
110. Stanhope Lens. This form of lens has great magnifying power, and occupies but a very small space in the pocket; mounted in ivory, horn, tortoiseshell, German silver or silver, 2s. 6d. to 12s.
111. Cloth Microscopes or Linen Provers for ascertaining the value of linen cloth, by enumerating the number of threads in a given space; folding for the pocket, 2s. to 4s. 6d.
112. Small Seed Microscope with glass tubular body and screw adjustment for focus, in case, 3s. 6d. and 4s. 6d.
113. Beetle Microscope with glass tubular body and screw adjustment for the focus, and a specimen of the Diamond Beetle mounted on a revolving pin, ready for examination, in a case, 12s.
114. Portable Flower and Insect Microscope of an extremely simple and useful form, 7s. 6d.
115. Small Pocket Compound Magnifier, provided with a silver speculum for viewing opaque objects, £1 1s.
116. Small-size Compound Microscope with sliding stage and three magnifying powers, in mahogany box, 12s. 6d.
117. Small-size Compound Microscope with sliding adjustment to the body, stage and silvered glass reflector, 3 magnifying powers, forceps, &c., in mahogany case, 18s.; and with condenser for opaque objects, £1 1s.
118. Small single Microscope with stage, rackwork adjustment, silvered glass reflector, 3 magnifying lenses, set of 18 objects, forceps, dissecting knives, &c., in morocco case, £2 2s.
119. Small-size Compound Microscopes with stage, rackwork adjustments, silvered glass reflector, 3 powers, forceps, dissecting knives, &c., in morocco or mahogany cases, £2 18s. and £4 4s.

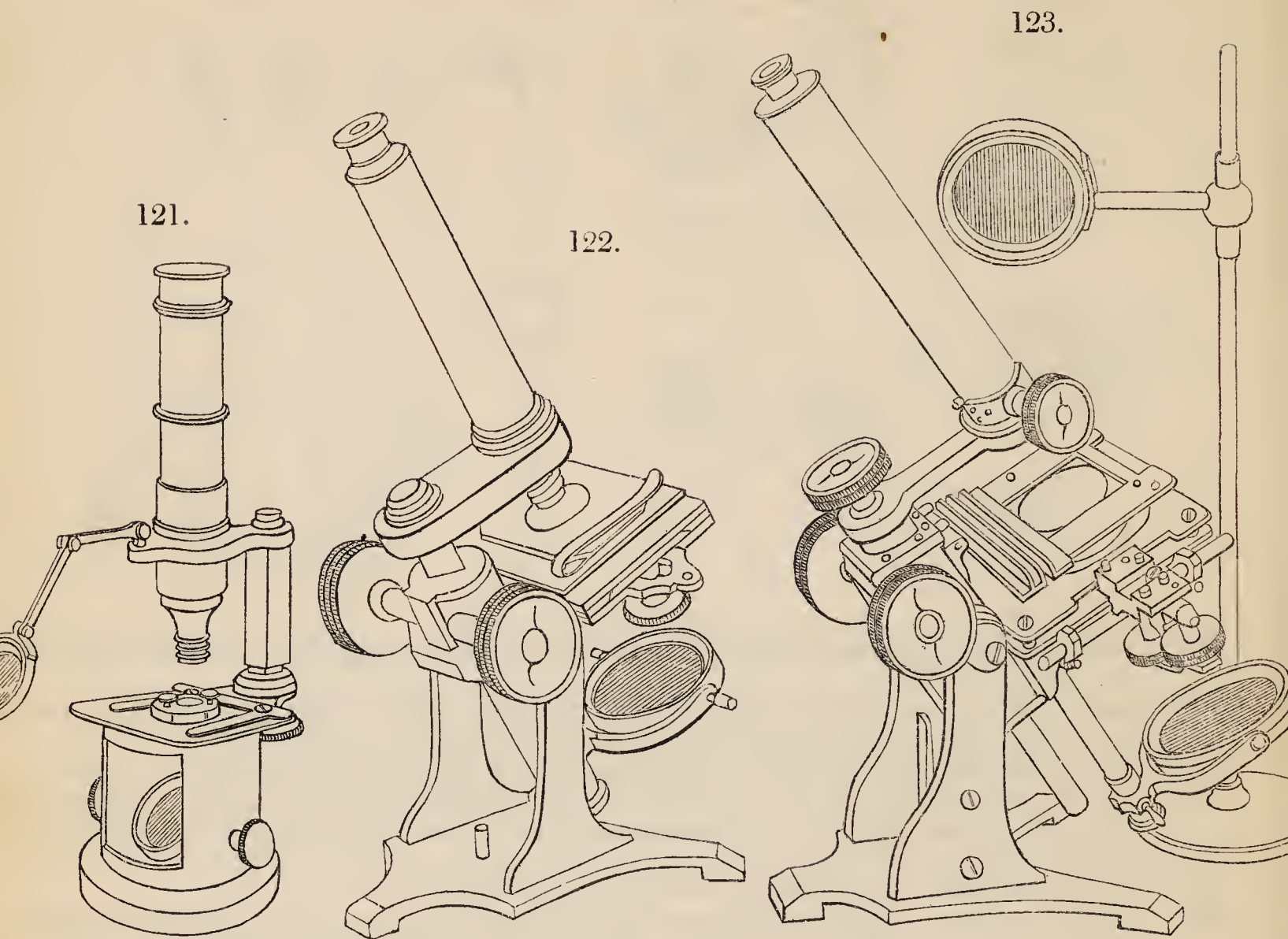

120. Middle-size Compound Microscope adapted for the use of students, with one eye-piece and 4 magnifying powers, knuckle-joint to the body for viewing objects at any angle, rackwork adjustment to the object-glass, spring clip to the stage, large silvered reflector, condensing lens for opake objects, live insect box, forceps, water troughs, set of superior objects; the whole neatly packed in a portable mahogany case, £7 17s. 6d.
121. Compound Microscope of a compact form, with 3 eye-pieces, 2 achromatic object-glasses, condenser for opake objects, fine adjustment to the body with objects, &c., in neat mahogany case, £15 15s.
122. Compound Microscope with achromatic object-glass, rackwork motion to the stage, objects, &c., in portable mahogany case, complete, £10 10s.
123. Best Compound Microscope with pillars and tripod stand, knuckle-joint for viewing objects at any angle, improved stage with double rackwork adjustments, and revolving spring clip, rackwork and fine screw adjustments to the body, sliding double silvered glass mirror, achromatic object-glasses, 2 eye-pieces, condensing lens on separate stand for opake objects, concave silvered speculum, detached forceps and pair of forceps with joint for attaching to the stage, live insect box, knives, &c., packed in a solid mahogany case with flush brass handle for convenience in carrying, £26 5s.; with the addition of Polarizing Apparatus, £2 2s. extra.
124. Very superior large size Compound Microscope with steady tripod stand, and double knuckle-joint for placing the instrument at any required angle, best stage with double rackwork adjustments, sliding and revolving spring clip, and diaphragm with apertures of various diameters, concave and plane silvered glass mirror with double motion and sliding adjustment, stout brass arm and steadying rod to the body, rackwork and fine screw adjustments to the object-glasses, condensing lens for opake objects, concave silvered specula, 2 eye-pieces, doublets and achromatic object-glasses, polarizing apparatus, forceps, frog plate, live insect box, knives, test objects, &c.; the whole packed in a mahogany case with flush brass handle, £31 10s.

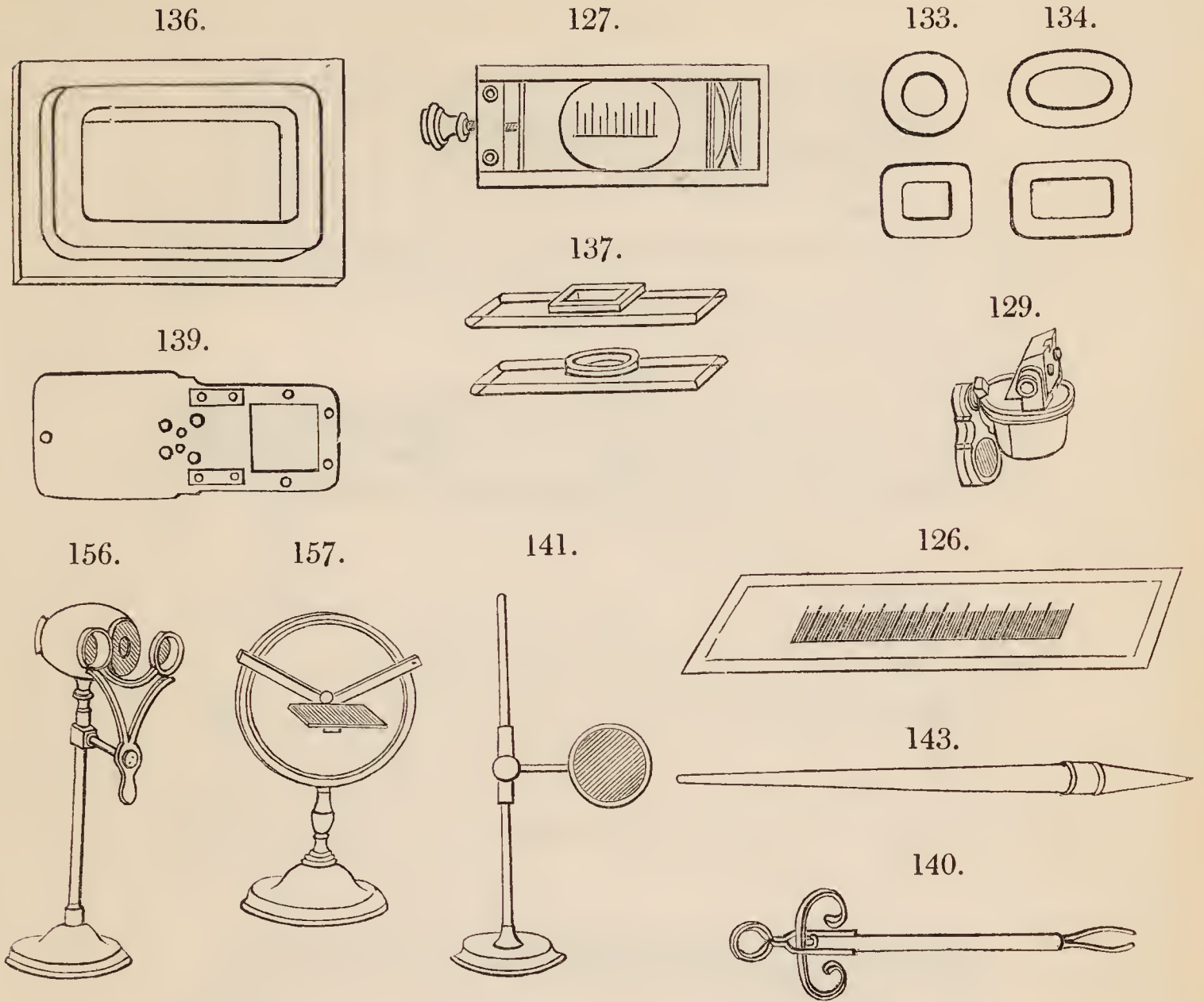

125. Achromatic Object-Glasses of the following foci, separate from the microscope, with brass mountings, each; 3 in. £1 10s.; 2 in. £1 15s.; 1 in. £2 2s.; $\frac{1}{2}$ in. £3 13s. 6d.; $\frac{1}{4}$ in. £5 5s.; $\frac{1}{8}$ th of an in. £7 7s.; and $\frac{1}{12}$ th of an in. £10 10s.
126. Glass Micrometers with finely divided lines for measuring the diameters of various objects, 5s. to 10s.
127. Glass Micrometers mounted in brass frames with fine screw adjustment, £5 5s.
128. Micrometers for the eye-piece and stage, 5s. to £1 5s.
129. Camera Lucida, adapted to the Microscope for taking magnified drawings of the objects, £1 1s. to £1 10s.
130. Apparatus for the Polarization of Light adapted to microscopes, £2 2s.
131. Glass Slides with polished cells, for mounting microscopic specimens, per dozen, from 2s. to 5s.
132. Plain slips of glass for mounting objects, with ground or polished edges, per dozen, 1s. and 1s. 6d.
133. Rings of Glass for mounting objects, per dozen, 2s. to 5s.
134. Squares of Glass for mounting objects, per dozen, from 3s. to 7s. 6d.
135. Thin plates of Microscopic Glass for mounting objects, at per oz. 6s. to 7s. 6d.
136. Cases of various sizes for live aquatic insects, 5s. 6d.
137. Cases with very thin glass covers for holding animalcules, 7s. 6d.
138. Set of Dissecting Instruments for microscopic purposes, in a case, £1 1s.
139. Frog Plate for illustrating the circulation of the blood in Frogs, &c., 15s.
140. Quekett's Forceps useful for taking hold of minute microscopic objects, in brass or German silver, 10s. 6d. and 15s.
141. Condensing Lens mounted on a brass sliding stand, 15s. to £1 5s.
142. Argand Oil Lamp with fountain reservoir, on a brass stand with sliding adjustment for regulating the height, with achromatic or blue glass chimney, £1 11s. 6d. to £2 2s.
143. Writing Diamonds mounted in brass or German silver with ivory or wood handles, for marking names on slides, 7s. 6d. to 10s.

153.

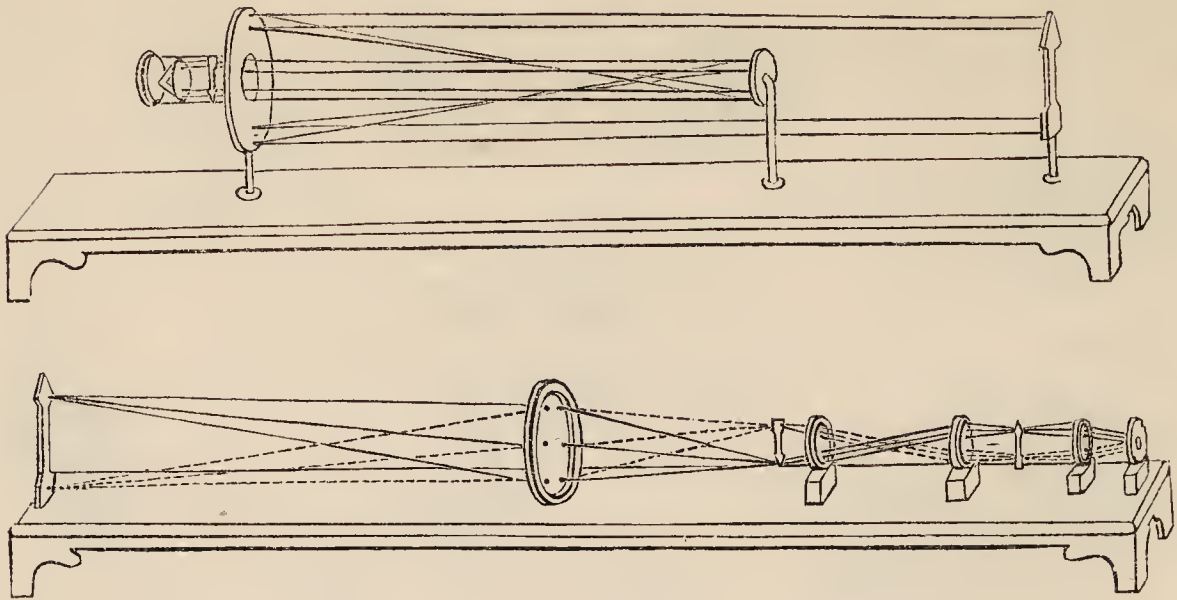

154.

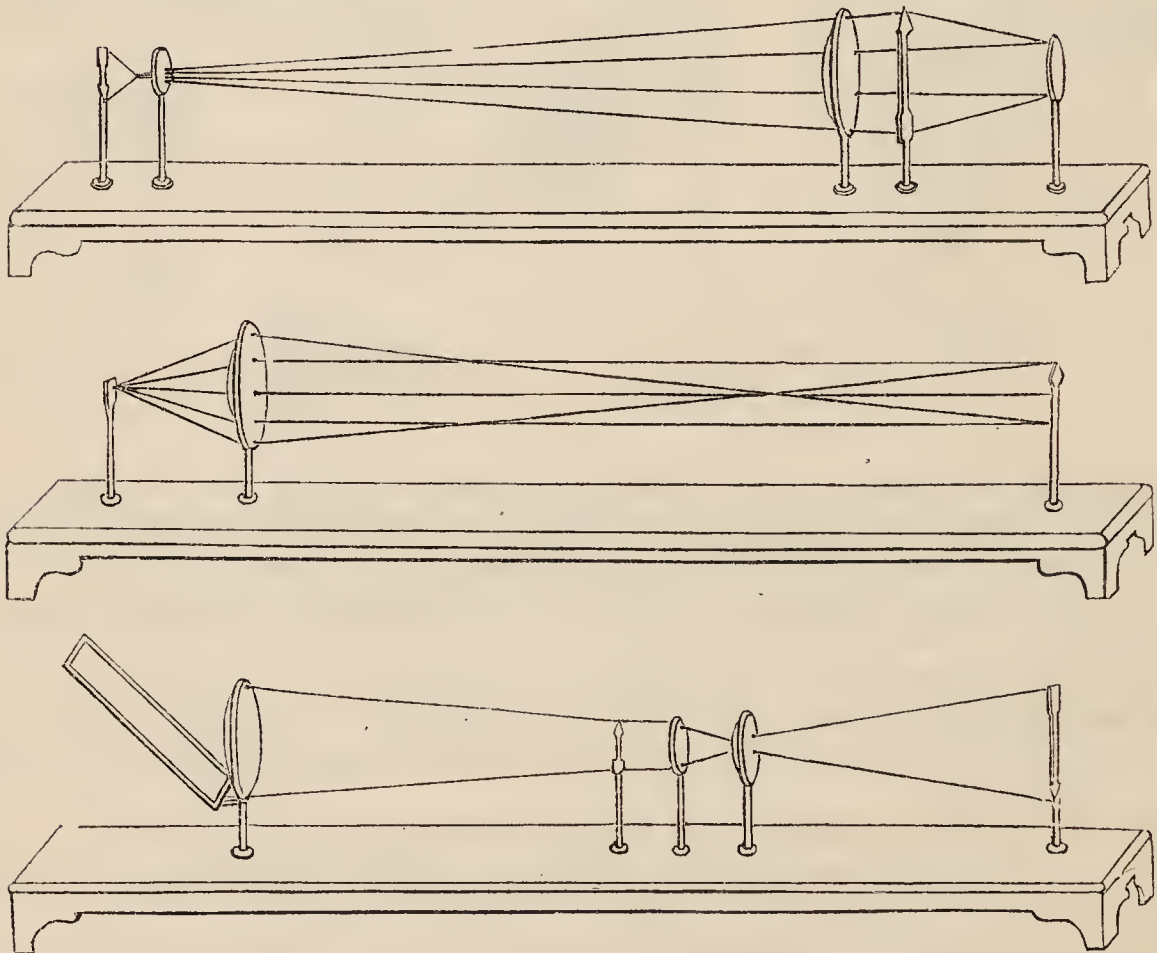

144. Ivory Sliders with prepared objects for the microscope, 4 on each slide, opaque or transparent, 3s. 6d. per set of three.
145. Objects mounted in glass slides, showing various portions of insects, the respiratory organs, &c., 1s. 6d. to 4s. 6d.
146. Glass Slides mounted with thin sections of fossil woods, three specimens on each, 4s. 6d. each.
147. Glass Sliders mounted with sections of fossil palms, bones, &c., two specimens on each, 3s. each.
148. Glass Sliders mounted with sections of granite, agates, 2s. each.
149. Glass Sliders mounted with sections of limestone, 1s. 6d. each.
150. Test Objects mounted in glass sliders, Navicula, Hippocampus, Podura, Brassica, Hair of Mouse, Bat, &c., 1s. 6d. to 4s. 6d.
151. Various objects for polarizing in the microscope, mounted in glass sliders, 2s. to 5s.

152.

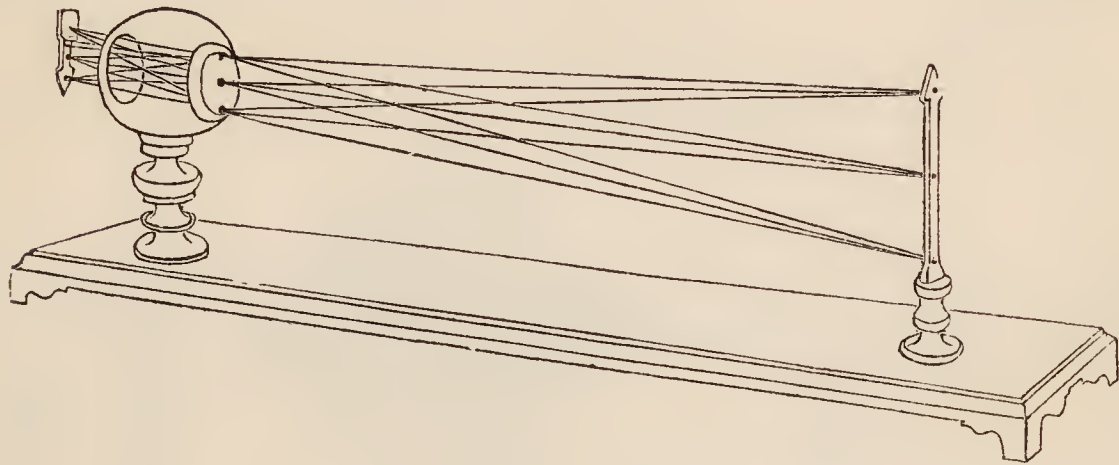
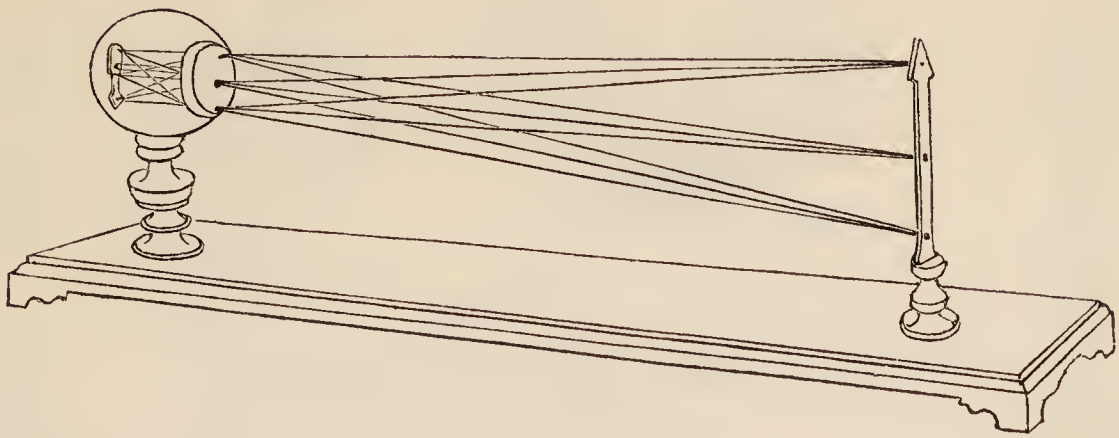

155.

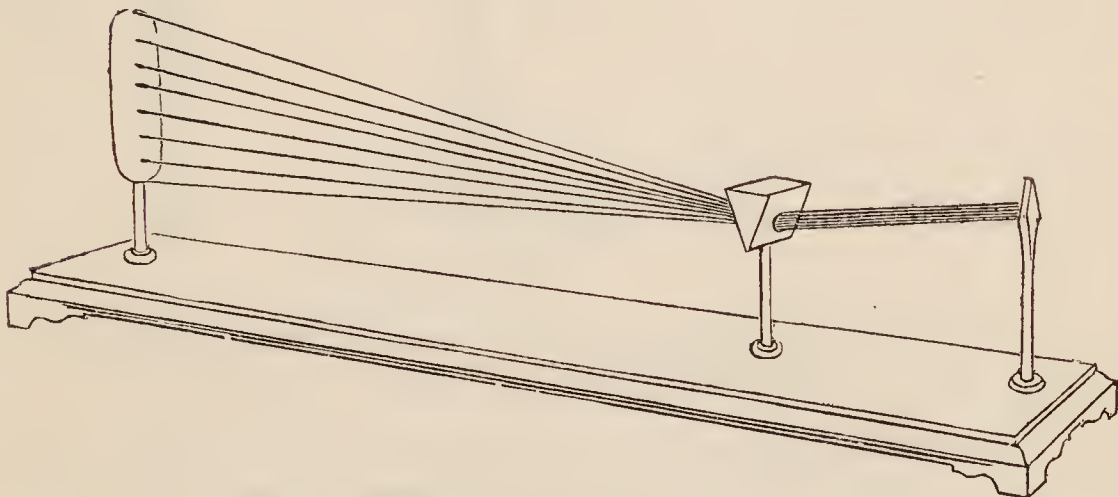

INSTRUMENTS FOR EXPERIMENTAL DEMONSTRATION AND RECREATION.

152. Set of Three Optical Models with the supposed path of the ray of light, represented by variously coloured silken strings, to illustrate the optical effect of vision, and also the conformation of the eye in its natural, long-sighted and short-sighted states, £3 13s. 6d. to £5 15s. 6d.
153. Set of Two Optical Models with the supposed path of the rays of light, represented by variously coloured silken strings, to illustrate the elementary principles of optics and their application to the construction of reflecting and refracting telescopes, £3 3s. to £4 4s.
154. Set of Three Optical Models with the supposed path of the rays of light, represented by variously coloured silken strings, to show the principles of the solar compound and simple microscopes, £3 3s. to £4 4s.
155. Apparatus to illustrate the decomposition of white light into colours by the prism. The prism is formed of brass, and the rays of the spectrum are represented by silken threads of proper colours, £1 1s. and £1 11s. 6d.
156. Apparatus to illustrate the eye or organ of vision with the different lenses formed in glass, the curvature of which is so contrived that rays of light proceeding from an object placed before the model are collected into a focus upon the retina, represented by a roughened glass. Two extra glasses are furnished to demonstrate the optical action of differently curved crystalline lenses; and also convex and concave glasses, to show how the defects consequent thereon are practically remedied, £1 1s., £2 2s., £5 5s. and £10 10s.

161.

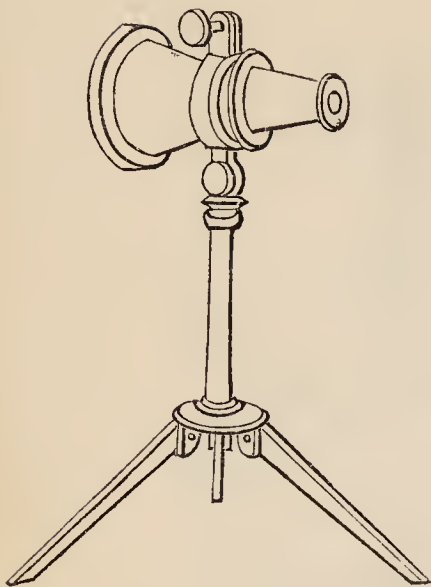

163



165.



166.

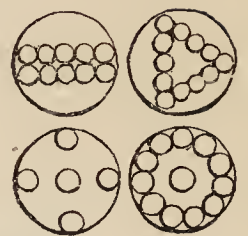

164.

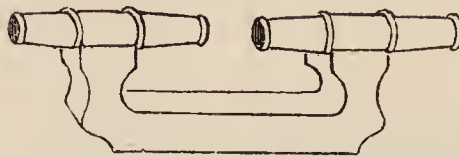

166.

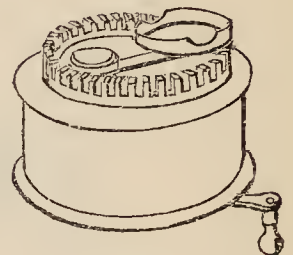

170.

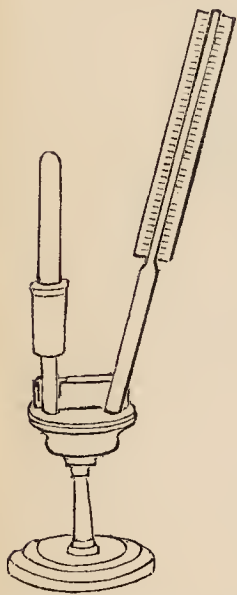

167.

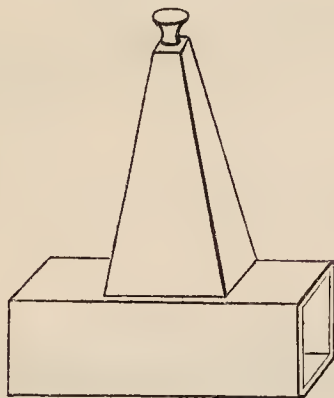

159.

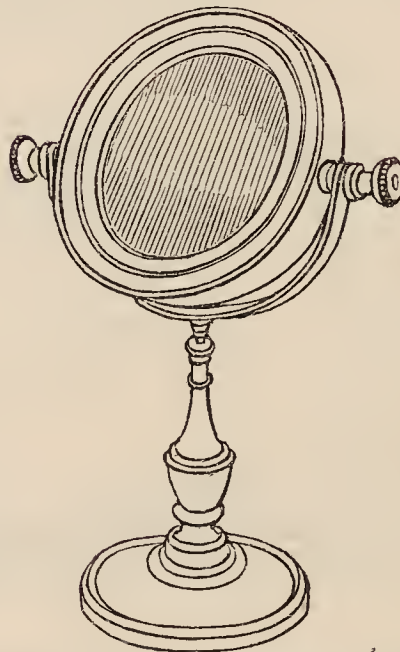

166.

169.

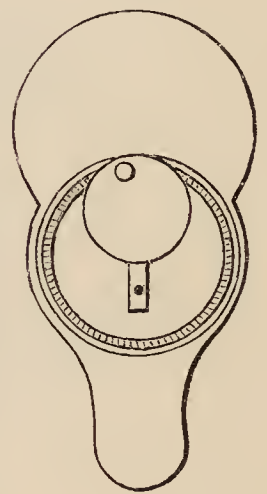

157. Apparatus like that invented by Ptolemy, for experimentally illustrating the law of refraction. It may also be employed to illustrate the law of reflexion, 18s., £1 10s. and £2 12s. 6d.
158. Cylindrical, Prismatical, Pyramidal and Conical Mirrors, for showing the curious properties of the several forms; some reflecting anamorphoses or distorted images of regular objects, while others again rectify those which are really distorted.
159. Concave, Convex or Plane Silvered Glass Circular Mirrors, optically worked and mounted in a swing frame with stand, 6 in. diameter, £1 11s. 6d. and £1 15s.
160. Concave, Convex or Plane Silvered Glass Circular Mirrors, optically worked, mounted in neat black frames of various diameters; 4 in. 12s. 6d.; 6 in. £1 1s.; 8 in. £1 13s.; 12 in. £3 3s.; 15 in. £4 4s.; 18 in. £7 7s.; 24 in. £15 15s.
161. Brewster's Kaleidoscope, with two reflecting planes at certain angles, which produce a circular field of view. This simple and amusing instrument affords an endless variety of beautiful and novel pictures, 10s., £1 1s. to £2 2s.
162. Concave Silvered Glass Mirrors, ground cylindrically for showing the deformation of objects reflected by this species of curved surface, 18s.
163. Small Silver-mounted Concave Mirror for examining the interior of the mouth, £1 1s.
164. Optical Paradox or Polemoscope; it consists of two perspectives attached by a tube bent twice at right angles; when a board is between them, and the eye placed at one perspective, all objects before the opposite one will be visible, as if no interruption in the line of vision had taken place, 12s., 15s. and £1 1s.
165. Lens for Multiplication of Images, the object being repeated as many times as there are planes disposed on the convex surface of the glass, 2s. 6d. to 7s. 6d.
166. Wheatstone's Photometer for measuring the intensity of light. This instrument far exceeds in accuracy and convenience any which has yet been contrived, and is founded upon the physiological principles of the permanence of the impression of light upon the optic nerve. This instrument is represented by the woodcut, with the single silvered bead-disc

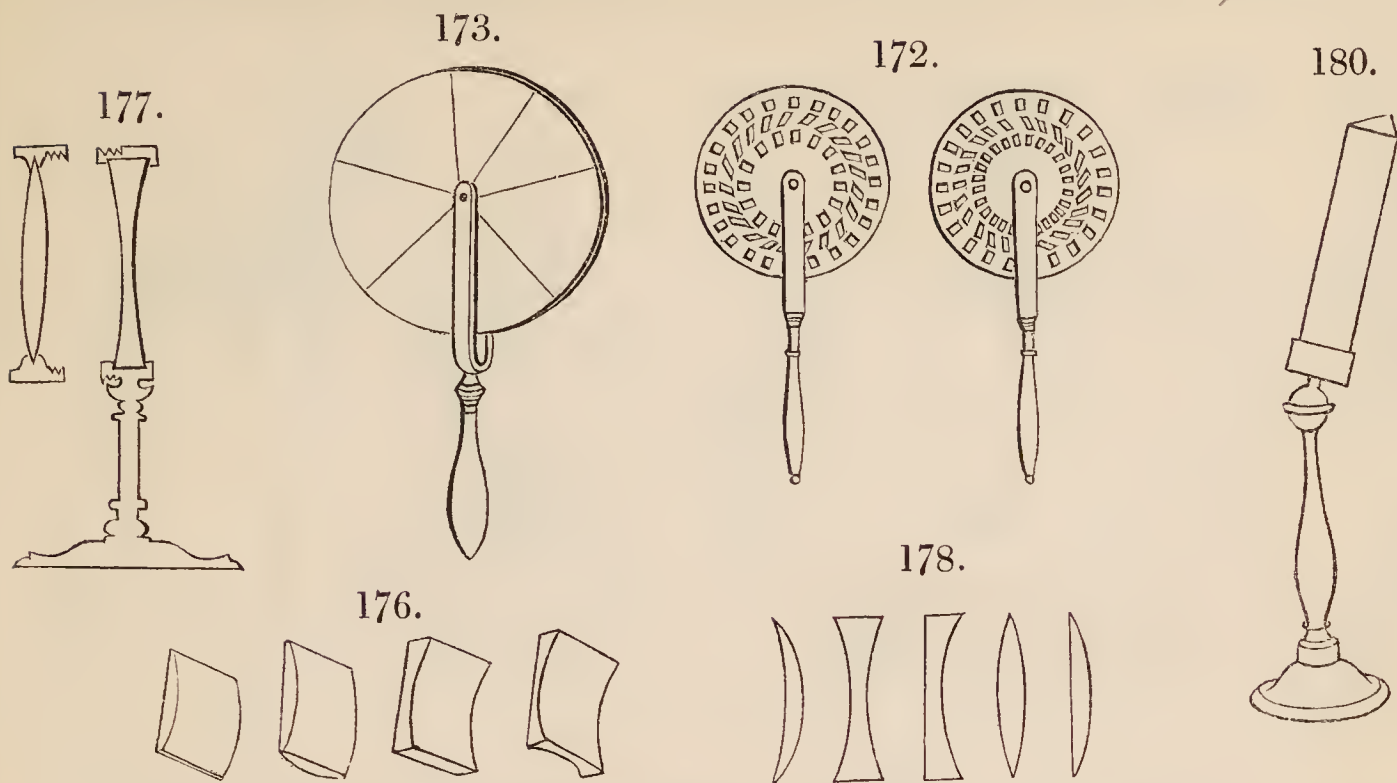

- attached in the position employed for estimating the relative values of two lights; but there are a variety of silvered bead objects furnished with the Photometer, which, when applied and the wheel made to revolve, present almost an endless variety of elliptical curves in brilliant lines of light, affording most interesting and pleasing optical phenomena, £1 1s. and £1 16s.
167. Ritchie's Photometer. In this instrument the different degrees of illumination are estimated by comparison. The two luminaries under experiment shine upon two rectangular plane mirrors, inclined at an angle of 45° ; the eye which sees at once the two degrees of illumination is the judge of the equality or inequality of their intensities, £1 1s. to £2 2s.
168. Leslie's Photometer. This elegant instrument is a modification of the Differential Thermometer, having one of its balls formed of black glass enamel, £1 10s. to £3 3s.
169. Photometer composed of a fine wedge of black or neutral tint glass, optically worked, mounted in a brass frame and case with a slit for admitting the rays of light. A rack-work movement may be applied to the wedge, and graduations for reading off the intensity of the light, of which the eye is the judge, 15s. to £4 4s.
170. Draper's Tithonometer, for measuring the chemical force of the indigo-tithonic rays. This instrument is remarkable for its extreme sensibility and exactitude, £1 11s. 6d.
171. Narrow strips of polished steel to bend into a concave form for the purpose of illustrating the principles of caustics and catacaustics by reflexion.
172. Simple and amusing Apparatus to show the peculiar class of optical deceptions, when wheels, either with cogs, radii, &c., are viewed in particular positions, and revolve in uniform and variable velocities, as noticed by Dr. Roget and Mr. Faraday, 5s. 6d. per pair.
173. Painted Circular Prismatic Plane. This contrivance exhibits the composition of white light from coloured rays, by the rapid revolution of the prismatic plane upon its axis, 10s. 6d.
174. Prismatic Plane mounted on stand with multiplying wheel, £1 5s.
175. Prismatic Plane painted on card for exhibiting the various colours composing the spectrum and their relative proportions, 2s. 6d. to 7s. 6d.
176. Set of Square Lenses of similar curvatures, fitted in a case, for showing the adaptation of plano-convex and concave, double convex and concave lenses to the cylindrical form. The lenses fit accurately to each other, and when combined become one plane lens, 18s.
177. Six Lenses of different curves on brass stands, for experimental demonstration on light, £1 16s.
178. Six Lenses of different curves in wood rings, £1 1s.
179. Apparatus to illustrate the intensity of light inversely as the square of the distance. It consists of a mahogany vertical plane with a small aperture in the centre, through which the light passes, and is received upon an accompanying muslin screen, arranged parallel to the plane of the aperture, 15s. and £1 1s.
180. Superior Flint Glass Equilateral Prisms, for illustrating the decomposition of white light, mounted on stands with ball and socket movement, 7s. 6d., 12s., 16s. and £1 1s.

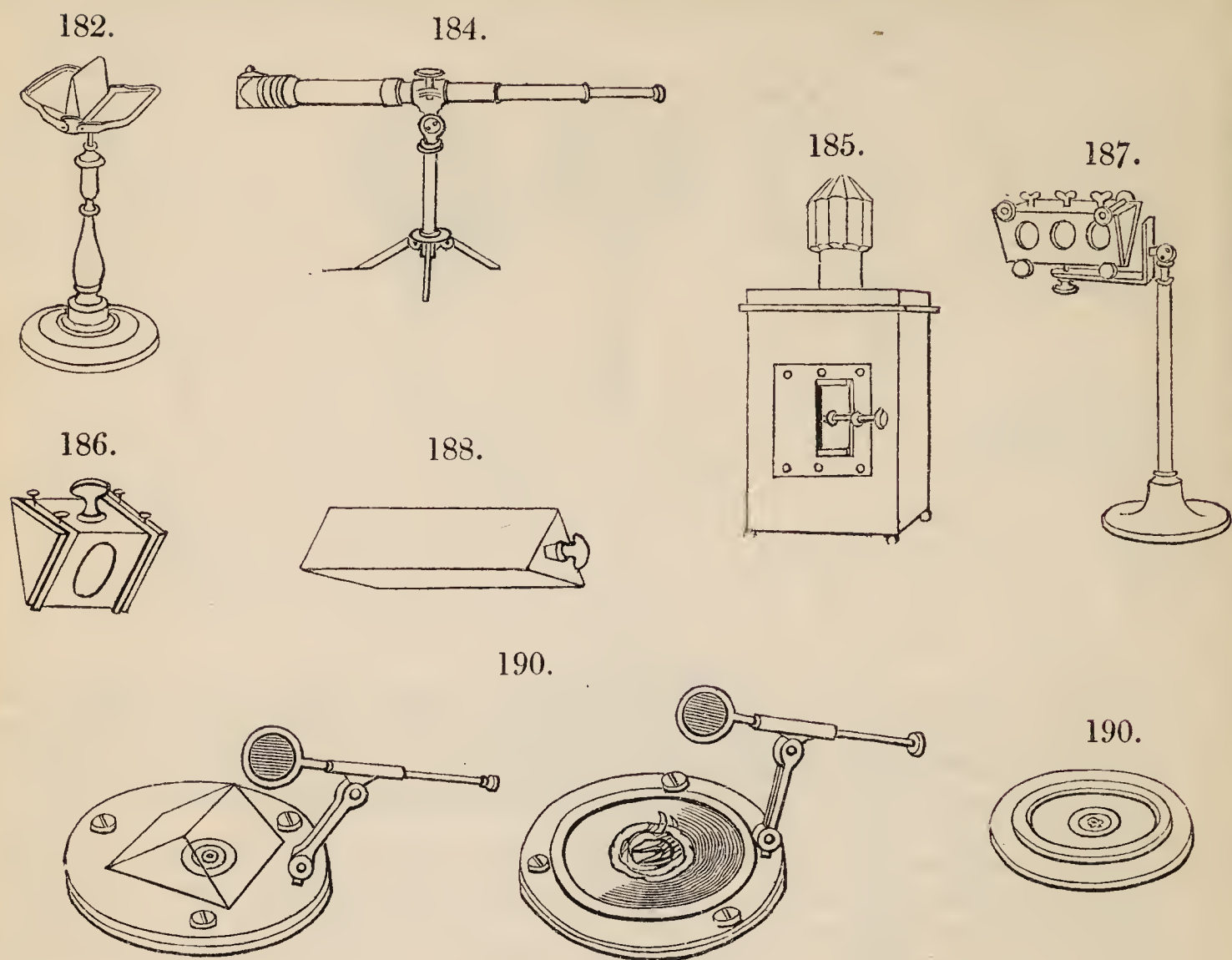

181. Glass Equilateral Prisms for showing the decomposition of white light, of various sizes and quality, 1s., 2s., 3s., 4s. 6d., 6s., 7s. 6d., 10s. 6d., 15s., £1 1s. and £2 12s. 6d.
182. Set of Small Prisms of plate, crown and flint glass, mounted in brass, for demonstrating the principles of the achromatic object-glass of telescopes, microscopes, &c., with stand, £1 15s., without stand £1 1s.
183. Prisms of plate, crown and flint glass, cemented together to illustrate the different refractive powers of these substances, 15s.
184. Achromatic Telescopic Arrangement, with brass stand and superior mounted equilateral glass prism, prepared by Mertz, successor to Fraunhofer of the Optical Institute, Munich, for observing by day with artificial light, Fraunhofer's dark bands which occur in the spectrum produced by prismatic refraction. The method of fitting up and managing the artificial light is very simple, and being always at command, the apparatus is applicable for experiments at all seasons of the year, £6 6s. and £7 7s.
185. Mahogany Lantern mounted on a stool, with brass slit, adjustable to various widths by a tangent screw, solar lamp and stoppered glass bottle for containing gaseous matter, to be used in conjunction with the Munich prism and telescopic arrangement, for viewing the fixed lines in the spectrum, £3 3s.
186. Hollow Prism, adapted for receiving different fluids, with ground stopper and moveable sides of polished parallel glass for experiments, with liquids of various refractive and dispersive powers, £1 1s. and £1 11s. 6d.
187. Hollow Prism mounted on brass stand, £3 3s.
188. Hollow Equilateral Glass Prisms with ground stoppers, filled with distilled water, from 10s. 6d. to £2 2s.
189. Hollow Prism for examining the refraction of liquids, mounted on brass stand with adjustments.
190. Apparatus for exhibiting the coloured rings reflected and transmitted by thin transparent plates, to illustrate Newton's Theory of the fits of easy reflexion and transmission. This apparatus may be composed either of two plain plates of glass, of a plain surface and a lens, or a plain surface and a prism, and can be fitted with a magnifying lens for examining the rings, 10s., 15s., £1 1s. and £1 5s.

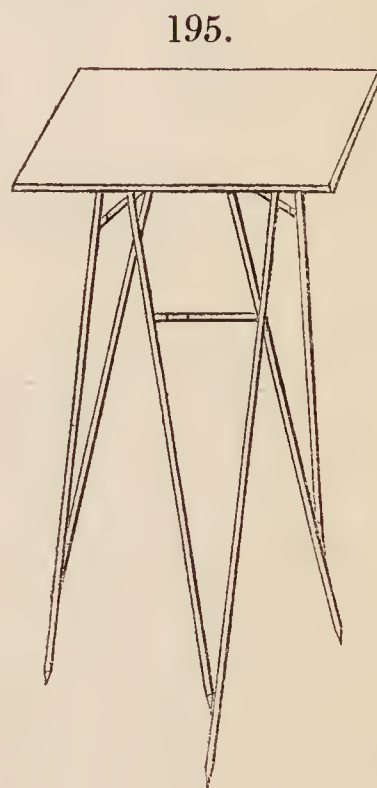
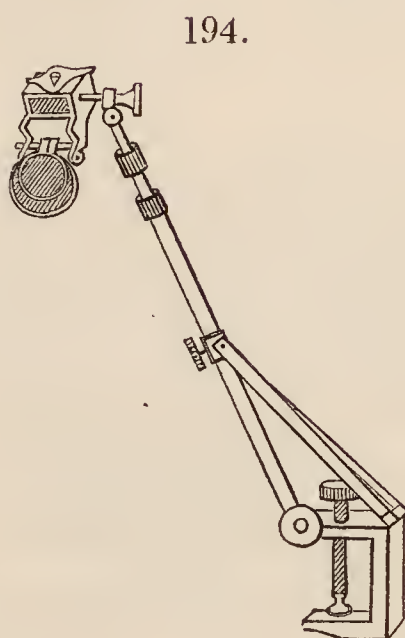
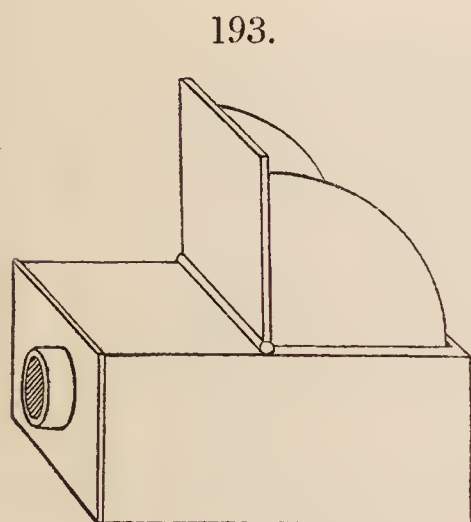
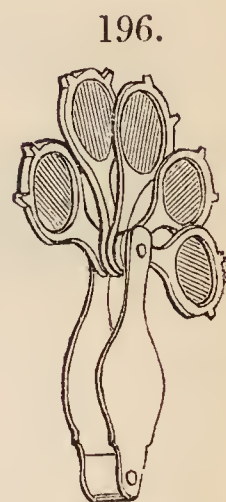
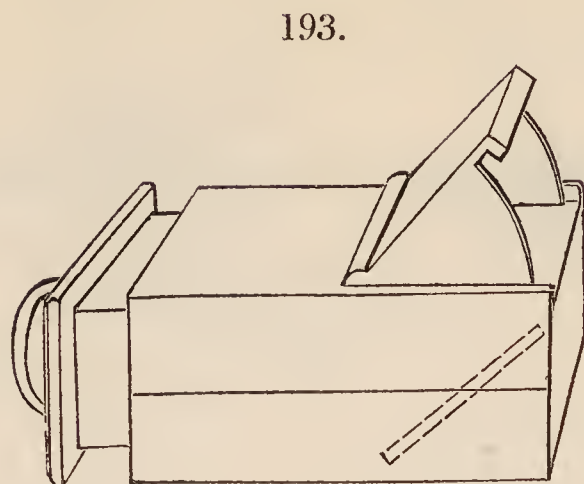
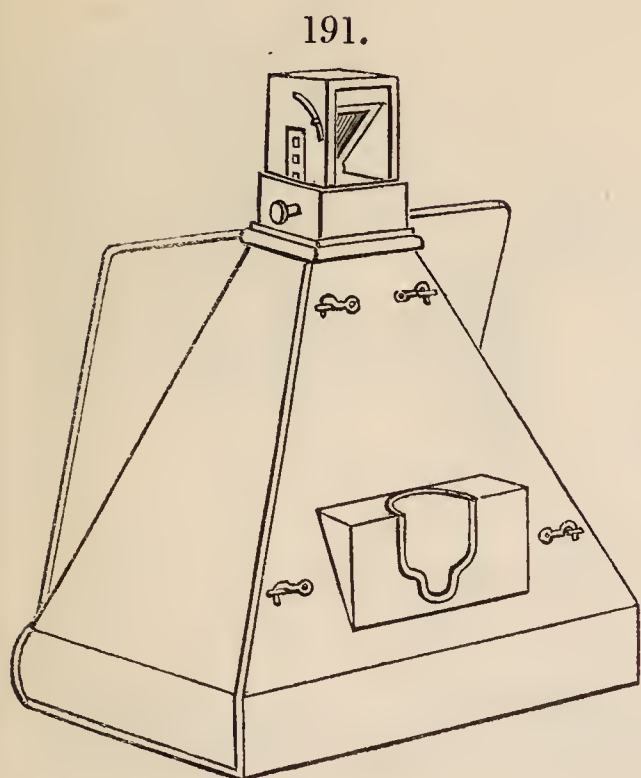

191. Camera Obscura, folding up as a neat portable chest or box, so as to be easily transported from place to place. This form of instrument has the advantage of the reflected image being viewed at once upon the paper intended for the drawing. No inversion takes place in the image, and a series of lenses are supplied for objects of different distances. By slight additions, this Camera may be converted into an instrument for magnifying prints and drawings, £2 12s. 6d., £4 4s. and £6 6s.
192. Lenses and Mirrors fitted to out of door Camera Obscuras, £5 5s.
193. Portable Camera Obscura, the arrangement of which is such that the images of external objects are represented on a rough ground glass plate. The image may be traced in outlines with facility by a black-lead pencil on the roughened surface; or if very thin white paper be placed upon the glass, the images are discernible and may be transferred to it in the same manner, 12s., £1 1s., £2 12s. 6d.
194. Wollaston's Camera Lucida. This simple and ingenious instrument is so portable, that it may with ease be carried in the pocket, and is therefore well calculated for the traveller. By its means a distant landscape may be delineated in perspective with the same facility as with the portable Camera Obscura, £1 11s. 6d., £2 12s. 6d. and £3 3s.
195. Portable Mahogany folding stand with table for the Camera Lucida, £1 1s. and £2 2s.
196. Claude Lorraine Glasses, for showing the effect of colour on pictures or real landscapes; this consists of a series of differently coloured glasses, mounted in a horn or tortoiseshell case, 2s. 6d. to 15s.
197. Optical Diagonal Machines for viewing perspective prints, £1 11s. 6d. to £2 12s. 6d.

198.

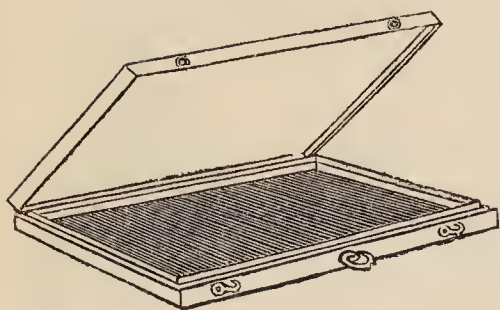

199.

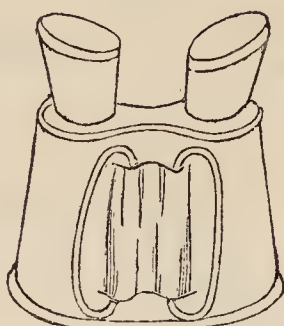

200.

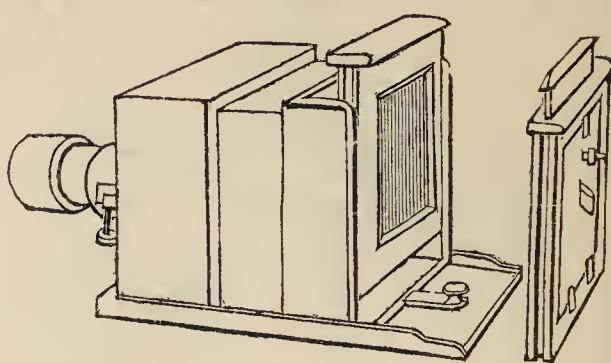

204.



203.

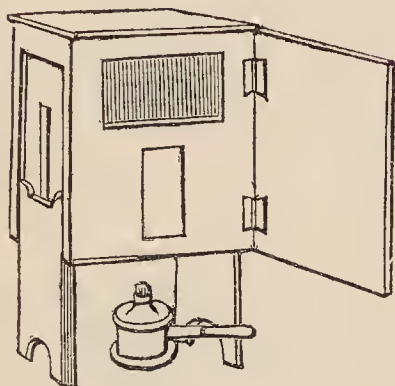

202.

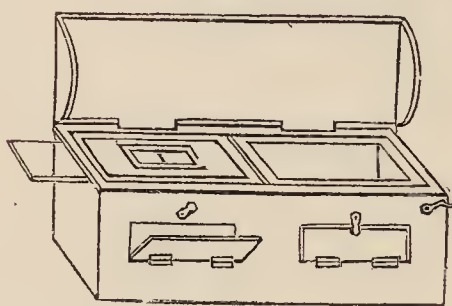

205.

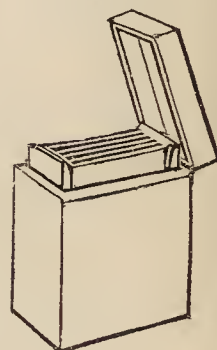

198. Black Glass Convex Mirrors in morocco cases, useful in facilitating the delineation of landscapes in perspective, 7s. 6d., 12s., 15s., £1 1s., £1 11s. 6d. and £1 18s.
199. Picture Tubes, double or single, in the form of an opera glass, of great use in galleries or other large collections of pictures in relieving the eye of the glare produced by variety of colour, and in concentrating the vision upon any desired point.
200. Mahogany Cameras for Daguerreotype pictures, with achromatic lenses mounted in brass tubes with sliding or rackwork adjustment, ground focusing glass frames for plates, &c., £3 3s. to £25.
201. Complete Sets of Daguerreotype Apparatus, with camera and frames for plates, bromine and iodine box, mercury box, support for plates, plate holder, mahogany box for plates, &c., in case complete, £5 5s. to £30.
202. Bromine and Iodine Box of mahogany, fitted with frames for plates, glass pans and covers, &c., complete, £2 2s. to £5 5s.
203. Mahogany Mercury Box with sliding legs, thermometer, iron cistern and spirit lamp, £1 1s. to £2 2s.
204. Buff Sticks covered with velvet for polishing the plates, 2s. 6d. to 7s. 6d.
205. Mahogany Boxes for holding twelve Daguerreotype plates, various sizes, from 3s. to 7s. 6d.
206. Claudet's Focusing Apparatus, £2 2s. to £3 3s.
207. Camera Obscura for taking Talbotype or Calotype pictures with ground glass, and one frame for paper and a single Meniscus lens, £2 15s.
208. Superior form of Camera for taking Talbotype or Calotype pictures, with achromatic object-glass mounted in brass with sliding tube or rackwork adjustment to the focus, mounted on a portable folding tripod stand, six frames for paper, copying frame for negative pictures, ground glass for focusing, boxes for prepared paper, &c., complete, £15 15s. to £30.
209. Wheatstone's Stereoscope. This beautiful instrument has the remarkable property of giving to two views or diagrams, of one object taken at different angles and seeming to the unassisted eye merely plain surfaces, an appearance when examined by the instrument of absolute solidity and atmosphere. The effects are capable of being multiplied to almost any extent, and the instrument is a valuable adjunct to portraiture by Daguerreotype. With a set of lithographic drawings and diagrams, 5s., 15s., £1 1s. and £1 10s.
210. Daguerreotype Plates of Busts, Statuary, Birds, and a variety of other pleasing objects, mounted for the Stereoscope, 10s. 6d., £1 1s. and £1 11s. 6d. each.

208.

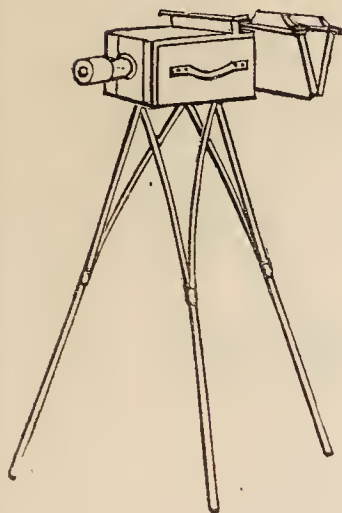

209.

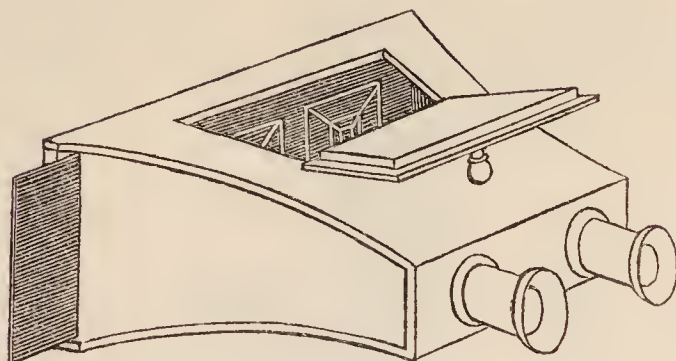

212.

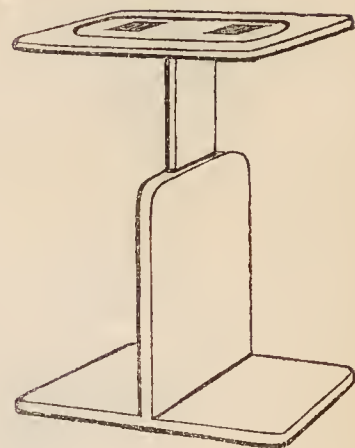

215.

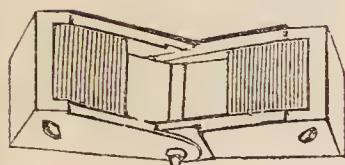

211.

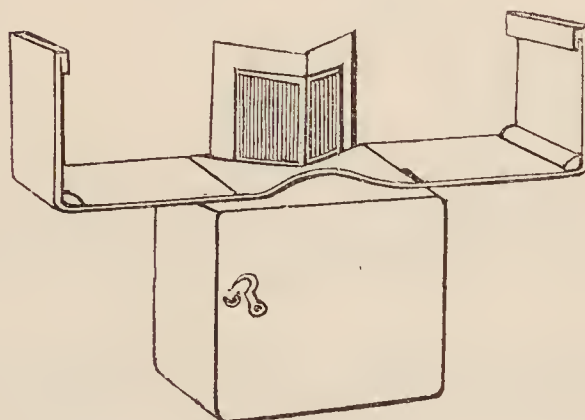

213.

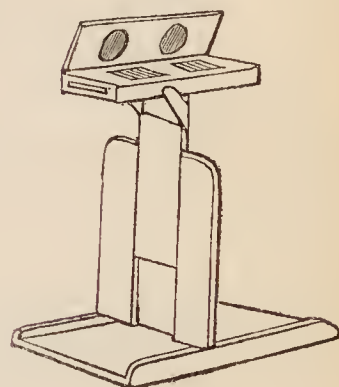

214.

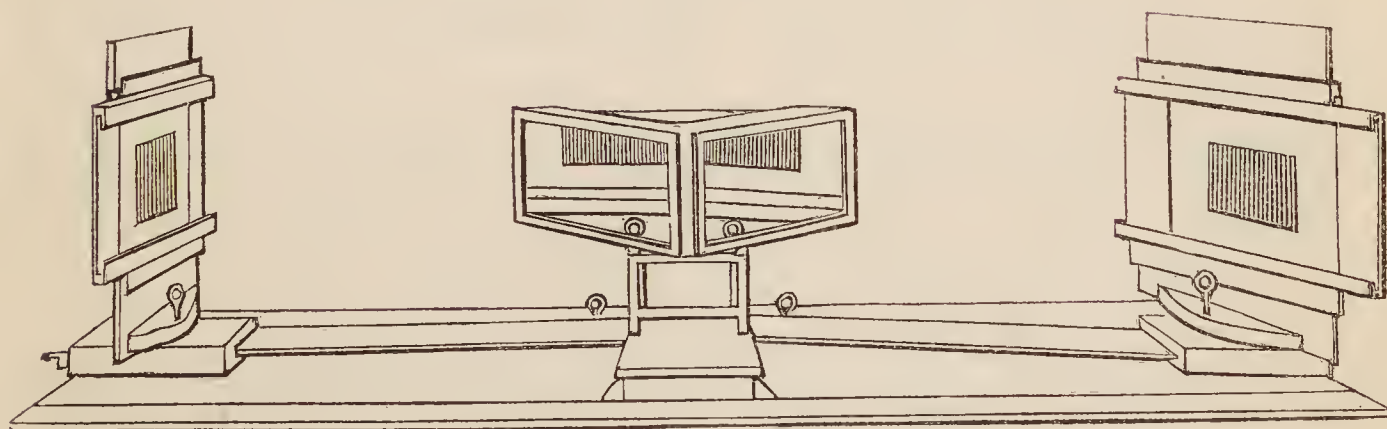

211. Wheatstone's Improved Portable Reflecting Stereoscope, for examining larger diagrams, and particularly adapted for Calotype drawings, folding up into a neat mahogany case with a set of diagrams; the reflexion produced by mirrors, £1 11s. 6d. The same instrument with reflecting prisms, £2 12s. 6d.
212. Wheatstone's simple Refracting Stereoscope, for viewing objects unaided by any magnifying power through two prisms, 15s., with a set of diagrams.
213. Portable form of the above instrument, folding up in a small space when not in use, and having the peculiar advantage of enabling the observer to examine objects either simply or with the aid of a magnifying power, 18s., with a set of diagrams.
214. Large Reflecting Apparatus for illustrating on an extended scale all the phænomena observed by Professor Wheatstone in his experiments on Binocular Vision. This apparatus is very effective for large drawings, prints or Calotype pictures, £1 11s. 6d. to £2 12s. 6d.
215. Wheatstone's Pseudoscope. This novel and remarkable instrument has the singular property of apparently reversing the condition of solid objects, such as rendering a globe hollow, causing a cup or hollow vessel to appear a sphere, cameo medallions to become intaglio, and intaglio to be cameo, besides other interesting and curious effects too numerous to mention, £1 10s. and £1 15s.

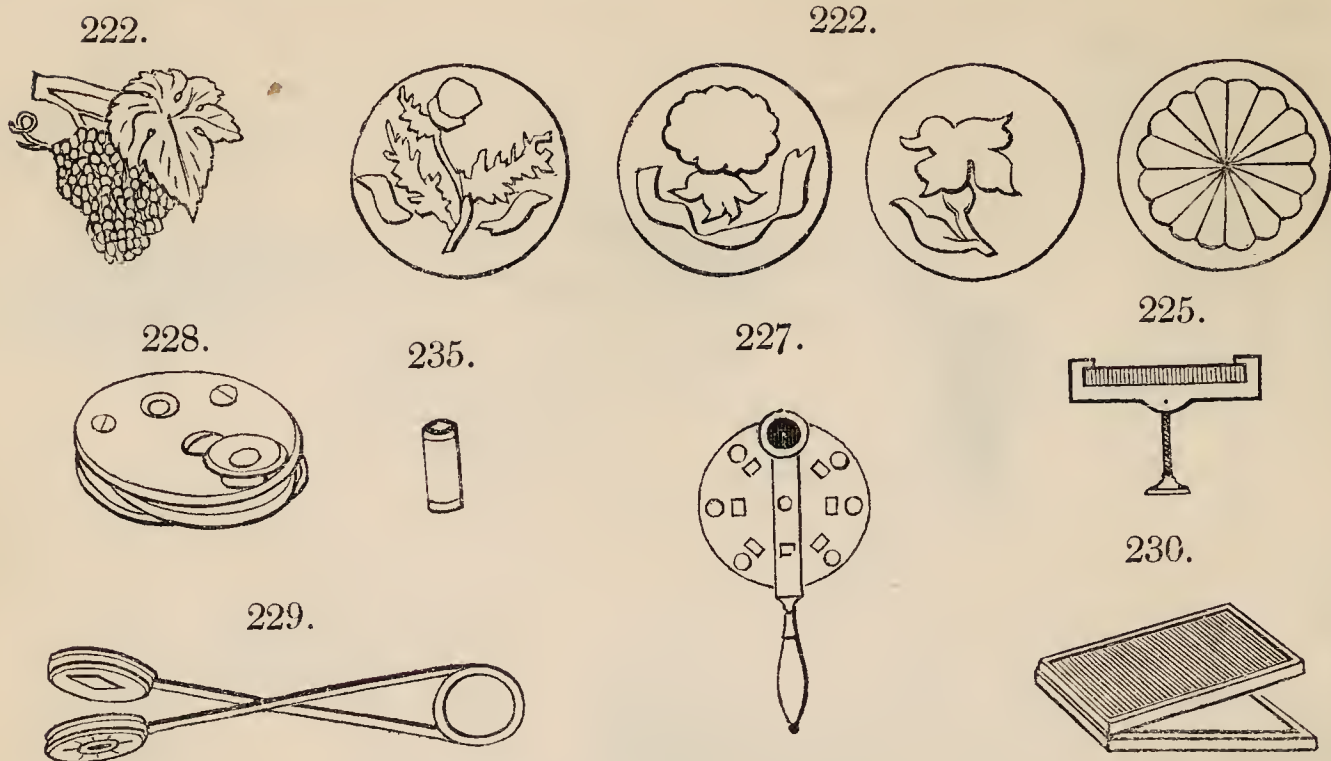

APPARATUS FOR ILLUSTRATING THE POLARIZATION, DIFFRACTION AND INTERFERENCE OF LIGHT.

216. Goddard's Reflecting Polariscopes, with microscopic lenses and mahogany lantern, to be used with the oxyhydrogen lime light. The phenomena of colours of polarized light are exhibited by this instrument with great intensity, and highly magnified on a semi-transparent or opaque screen, suited for the purposes of popular demonstration. This Polariscopes not only shows the films of selenite arranged as flowers, stars, fruit and wedges, but it displays most beautifully on an extensive scale the systems of coloured rings surrounding the optic axes of crystals. Without objects, £7 7s.; with objects, in case complete, £15 15s.
217. Solar Polariscopes. This instrument, by the aid of the sun's rays, shows all the beautiful phenomena of polarized light on a wall or screen in a manner quite equal if not superior to the Oxyhydrogen Polariscopes; and in climates where the sun is almost at command, it relieves the lecturer of all the operations of generating gas consequent on the use of the lime light; with brass body and 5 in. condensing lenses, £13 13s.
218. The Oxyhydrogen Lime Light Apparatus adapted for the Polariscopes, is in every respect similar to that already described for the microscope, No. 97 and 98.
219. Mounted Double Image Prisms, fitted to the Oxyhydrogen Polariscopes for the illustration of polarized light by double refraction. The separation of the images is exhibited on an enlarged scale on the screen in colours always complementary to each other, and when the two images are blended together or superposed, they appear formed of white light, 12s.
220. Objects mounted for the Oxyhydrogen Polariscopes, consisting of polished plates of carbonate of lime, beryl, arragonite, nitre, Brazilian topaz, Rochelle salt, sulphate of barytes, crystallized sugar, borax, amethyst, &c., cut perpendicular to their axes, to show the splendid phenomena of coloured rings produced by the action of these crystalline bodies on polarized light, from 5s. to 10s.
221. Selenite objects, fitted into mahogany frames with rackwork movements for the Oxyhydrogen Polariscopes. The films of selenite are prepared in various devices, such as stars, &c., which may be made to revolve parallel to fixed superposing films of uniform tints, £1 1s. to £3 3s.
222. Selenite objects mounted in plain mahogany frames, consisting of stars, wedges, fruit, flowers, gothic windows, cubes and natural cleavages, &c., 2s. 6d., 5s. 6d., 7s. 6d., 10s. 6d., 15s., £1 1s. to £5 5s.
223. Specimens of polished Unannealed Glass mounted in mahogany frames, for exhibiting by the Oxyhydrogen Polariscopes, the peculiar and permanent polarizing structure of glass that has been uniformly heated and suddenly cooled, 4s. 6d. each.
224. Sections of Quill for showing its polarizing structure, formed either in figures or in plain cuttings, 3s.

216.

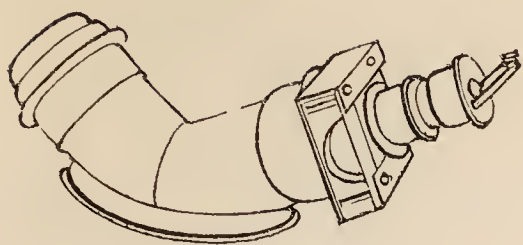

232.

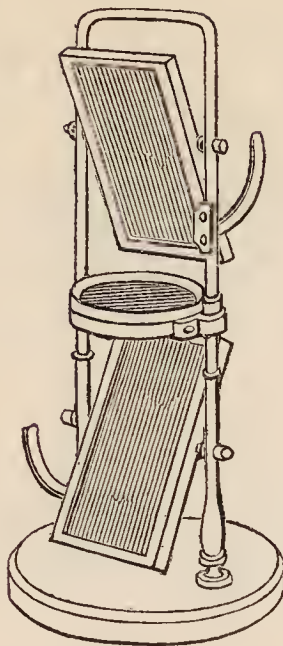

239.



236.

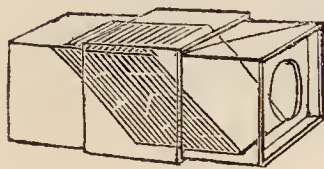

233.

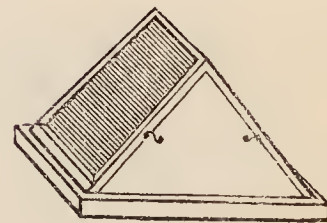

225. Apparatus adapted to the Oxyhydrogen Polariscope, to show the double refractive property communicated to plates of glass by mechanical pressure, 5s. 6d. and 7s. 6d.
226. Tourmaline Polariscope mounted in brass, with a contrivance to adjust at pleasure the axis of the two tourmaline plates, between which are arranged polished plates of various crystals, to illustrate the system of coloured rings in crystals with one or two axes of double refraction, £2 2s. to £3 3s.
227. Very superior Tourmaline Polariscope mounted in a variegated wooden frame, with a revolving wheel carrying the system of crystallized plates, which may be successively brought between the tourmaline plates; either of the latter can also be made to revolve in their own plane, and thus place their axes parallel or perpendicular to each other at pleasure, and vary the observed phenomena of each crystal, £3 3s. and £4 4s.
228. Tourmaline Polarizing Apparatus, to illustrate the phenomena produced by the combination of coloured rings from two polished crystalline plates, and the interposition of certain crystalline films between them. The arrangement is such that one plate has a double vertical motion and the other a universal motion, by which means not only the obliquity of the axes in the plane of their sections, but any obliquity may be effected in the crystals, £2 12s. 6d.
229. Polariscope consisting of two polished plates of tourmaline mounted in a pair of forceps, in such a manner that prepared plates of any crystal may be introduced between them for examining the system of coloured rings. The axes of the tourmaline may be readily made parallel or at right angles, 10s. to £1 1s.
230. Lecount's Polariscope, consisting of a silvered plain glass mirror and a pile of very thin glass plates, mounted in a mahogany frame with a contrivance for fixing the plates at the polarizing angle, 15s. to £1 10s.
231. Biot's plain Black Mirror Polariscope with brass tube, pillar and stand, for experimenting with polarized light by reflexion, having a contrivance for readily adjusting the polarizing mirrors in the polarizing angle, £3 3s.
232. Goddard's enlarged arrangement of the Reflecting Plane Polariscope, with graduated quadrants. The light is polarized by a pile of thin glass plates, and analysed by a plain black mirror. With this instrument, specimens of unannealed glass and selenite objects may be studied and exhibited with facility, £2 2s. and £3 3s.
233. Portable Reflecting Polariscope, consisting of a black mirror and a folding mahogany roof with glass sides, adjusted to hold objects at the proper polarizing angle. One great advantage of this little apparatus consists in the simple addition of a piece of greyed glass rendering it serviceable for exhibiting the effects of polarization by ordinary lamplight. In a case complete, £1 5s.
234. Polished Plates of Tourmaline, for observing with any reflecting plane surface the most marked phenomena of polarized light, mounted in wood or brass cells, 2s. 6d., 5s., 7s. 6d., 12s., 15s., £1 1s., £1 11s. 6d. to £5.
235. Nicol's Single Image Calc-Spar Prismatic Eye-piece. This eye-piece possesses the powerful polarizing energies of the tourmaline, united with perfect whiteness and transparency. Being colourless, it is superior to tourmalines for examining the most delicate tints of the rings of crystals, 7s. to £1 5s. Mounted in brass cases, 2s. extra.

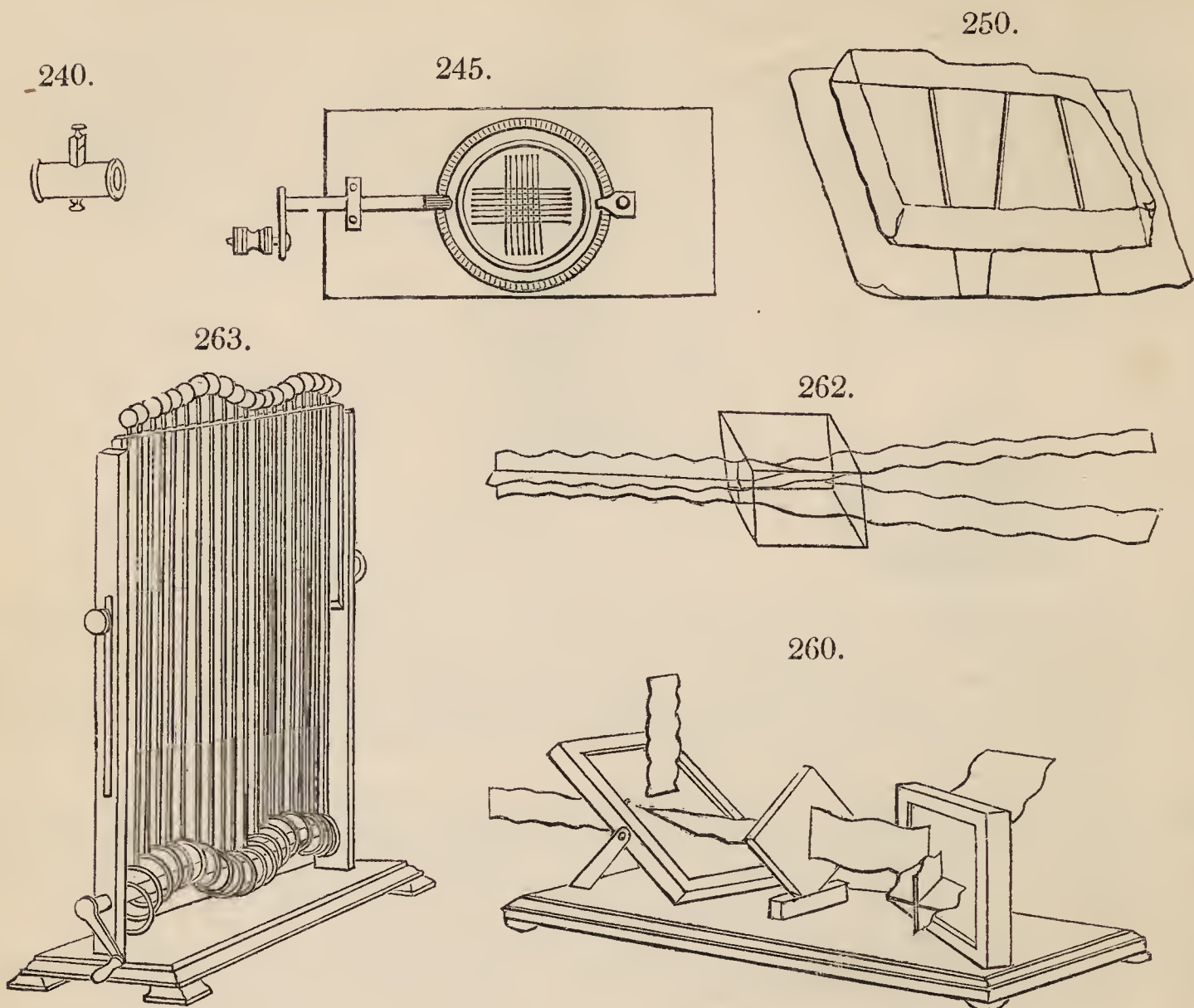

236. Polarizing Eye-piece, composed of a pile or bundle of small and exceedingly thin flat glass plates fitted into a pocket case, 4s. 6d. to 6s. 6d.
237. Piles or Bundles of very thin flat Glass Plates, fitted into frames of various sizes, either wood or metal, for experiments on the polarization of light by reflexion or refraction, 10s. to £1.
238. Mica, with the laminæ separated so as to form a pile of thin plates having the same relative positions as before their separation. A piece of apparatus of this description is at times useful with polarized light by reflexion as well as by refraction, 10s. 6d. to £1 1s.
239. Specimens of Polished Glass of various figures, to illustrate the peculiar and permanent polarizing structure of glass that has been uniformly heated and suddenly cooled. They exhibit coloured phænomena of astonishing variety and beauty, by forming fringes, irises and patterns of exquisite regularity and richness, 2s. 6d. to 4s. 6d.
240. Cooper's Tube arrangement for the polarization of light by double refraction, which exhibits the separated images in colours always complementary to each other; but when the two images are blended together or superposed, they are shown formed of white light, £1 12s.
241. Cooper's Polarizing Kaleidoscope. The endless variety of novel pictures presented by the kaleidoscope are each of them exhibited by polarized light, in successively varied tints, produced by polarized light, £2 2s. and £3 3s.
242. Plates of Polished Quartz of different thicknesses, to exhibit the change in the observed phænomena due to various thicknesses of the plates, 5s. to 7s. 6d.
243. Pair of thick Polished Plates of right- and left-handed Quartz, to show the dichroism, turned on the right and on the left hand by the direction of rotation of the analysing plate. In order to analyse this remarkable property of the two peculiar crystals of quartz, homogeneous light should be employed, 10s.
244. Two Polished Plates of Quartz, each to show parallel fringes with homogeneous polarized light; but when placed across, they exhibit coloured parallel fringes with common polarized light, 10s.

264.

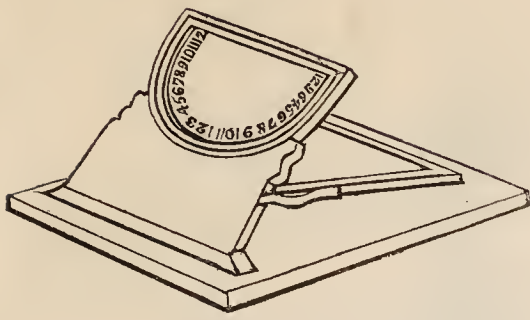

265.

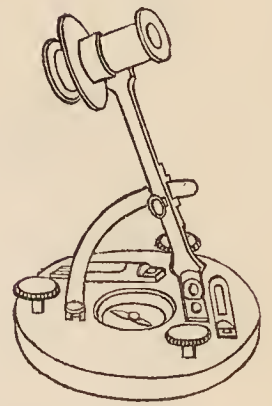

265.

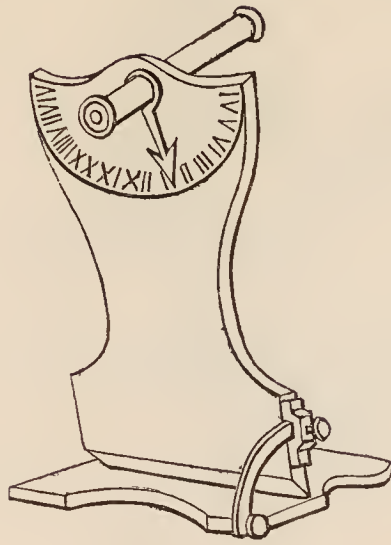

261.

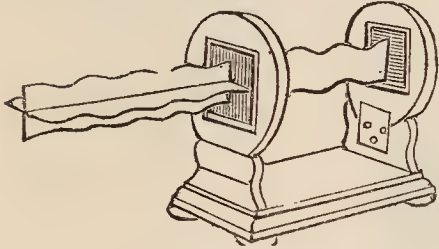

259.



245. A pair of very thin Wedges of Sulphate of Lime, for illustrating the coloured fringes parallel to their edges, thus showing the various tints produced by different thicknesses of the crystal, mounted in a frame with rackwork motion, £1 1s.
246. Plates of Calc-spar, with natural figure and polished surfaces, to see the parallel fringes in homogeneous light when placed between two tourmaline plates, 5s. to 7s. 6d.
247. Two Plates of Calc-spar, with natural figure and polished surfaces, placed across to show the parallel coloured fringes with common light when situated between two tourmaline plates, 10s.
248. Polished Plate of Nitre cut from a twin crystal, so as to show in the same field of vision four axes, 6s.
249. Plate of Brazilian Topaz parallel to the laminae, arranged under 45° , to exhibit in the same field of view both of the coloured systems due to its two axes of double refraction, 6s.
250. Natural Rhomboidal Crystals of Calc or Iceland Spar, to illustrate and experiment with double refraction, 2s. 6d. to £2 2s.
251. Double Refracting Iceland Spar Prisms, so prepared that a considerable angular separation of the double images is exhibited, 10s. to 16s.
252. Double Refracting Quartz Prism, constructed to show an increased angular separation of the two images, which are both achromatic, 10s. to 16s.
253. Achromatic Compound Prism of Calc Spar and Glass, mounted in brass protecting case. This prism exhibits the two images largely inclined towards each other, and hence it is valuable in illustrating the phenomena of double refraction, 12s.
254. Specimens of Iceland Spar prepared for illustrating the two white rings observed in certain specimens of the crystal when looked through at a lighted candle in a darkened room, 5s. to 7s. 6d.
255. Specimens of Iceland Spar, to show the multiplication of images afforded by peculiar structure of the crystal when looked through at a lighted candle in a darkened chamber, 5s. to 7s. 6d.
256. Mounted Polarizing Agate Plates, 5s.
257. Concave and Convex Plates of Selenite for concentric coloured rings.
258. Different sized Plane Mirrors of Glass with parallel surfaces, the under one roughened and blackened, mounted in suitable frames to be used as reflecting planes in experiments with polarized light, 7s. to £1 1s.
259. Card Model of a ray of ordinary light, showing two planes of vibration, 4s. 6d.
260. Model for illustrating the action of the Oxyhydrogen Polariscopes in the polarization of light, £2 12s. 6d.
261. Model for illustrating the nature and properties of two Tourmaline Plates in polarizing light, £1 1s.
262. Large Hollow Glass Model of the Rhomb of Iceland Spar, with cards to illustrate the separation of the ray of light by double refraction, 18s.
263. Powell's Apparatus for the popular illustration of plane, circular and elliptical vibrations, £3 13s. 6d.

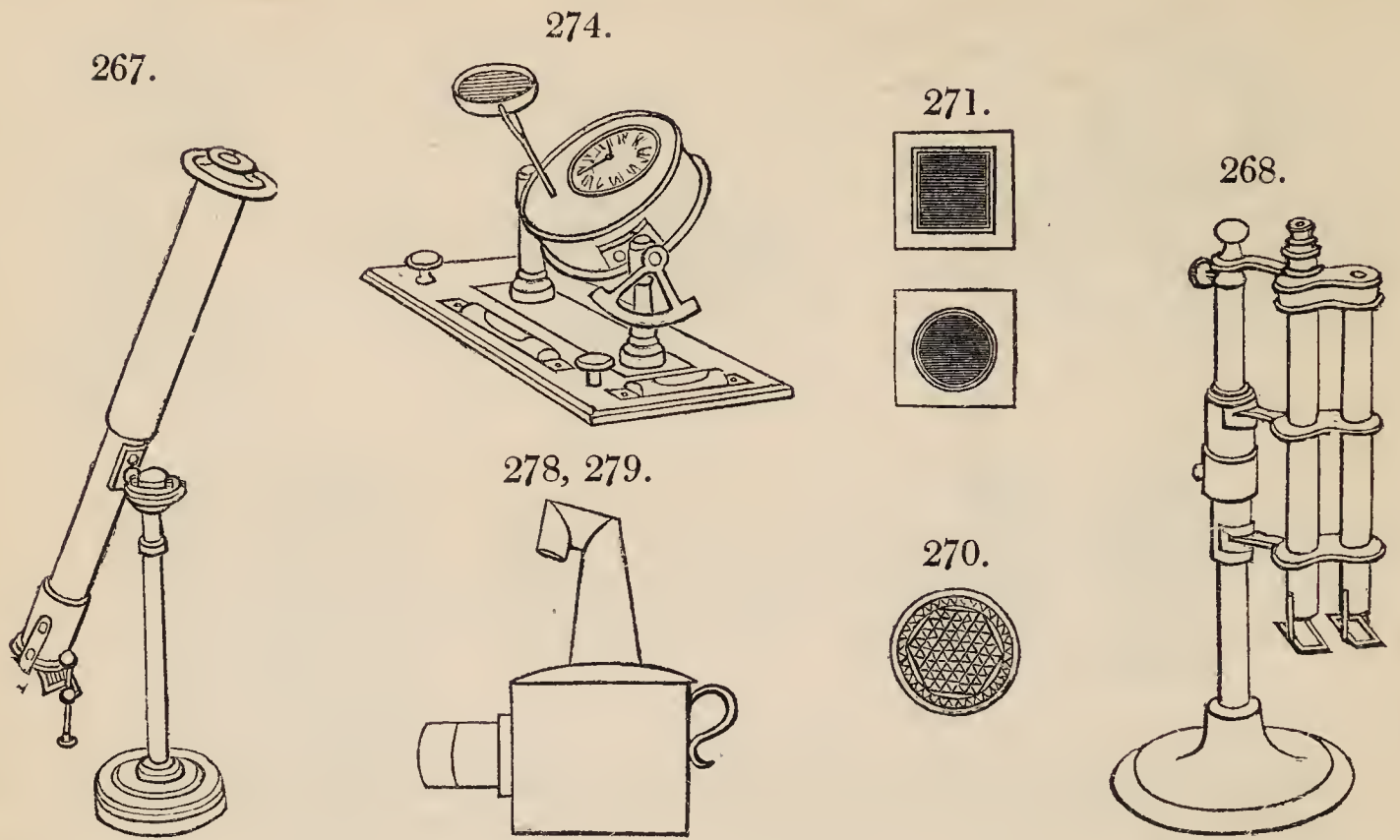

264. Model to illustrate the principle of Wheatstone's Polar Clock, £1 1s.
265. Wheatstone's Polar Clock for showing the hour of the day by the polarizing power of the atmosphere. This apparatus is of a large size, and is intended for use as a fixed instrument, £2 12s. 6d.
266. Portable form of Wheatstone's Polar Clock. This instrument is made on a small scale for the convenience of carrying in the pocket; it has all the necessary adjustments, and is provided with spirit levels, and a magnetic compass, and packs in a neat case, £2 12s. 6d.
267. Biot's Apparatus for examining the circular Polarization of Fluids, consisting of a glass tube for holding the liquid, with silver stops, mounted in a brass case on a ball and socket stand, with a plane black mirror, polarizing plate, and a double refracting achromatic analysing prism, £4 4s.
268. Powell's Apparatus for examining the circular Polarization of Fluids, consisting of a series of glass tubes of various lengths, capable of being mounted in brass adjusting tubes, with polarizing mirror and analysing prism, mounted on brass stand complete, £8 8s.

DIFFRACTION, &c.

269. Reade's Iriscope, consisting of a polished black glass plane mirror with its surface covered by a thin dried film of fine soap, which when breathed upon through a glass tube, exhibits a series of brilliant coloured rings by the vapour deposited, 10s.
270. Barton's Iris Buttons, to illustrate the prismatic or iridescent appearance of white light reflected from grooved surfaces. The phenomena are shown by the sun's or oxyhydrogen line light, and the iridescent image may be thrown on to a screen or the ceiling of a darkened chamber, with the most beautiful effects, 7s.
271. Fraunhofer's Gratings or Screens, from the Optical Institute of Munich, of very fine parallel equidistant right-lined and curved lines, ruled in gold leaf on plates of glass, £2 2s. and £2 12s. 6d.
272. Prisms with equal angles mounted on silvered plane reflecting mirrors, for illustrating the interference of light; with or without microscopic arrangement.
273. Prisms for interference of light, with very obtuse angles, 5s. each.
274. Potter's Heliostat. This instrument, so useful in many optical experiments where the sun's light is required to be reflected on a given spot for a length of time, is of a simple and convenient form, motion being given to the mirror by a watch movement. It is provided with levels, leveling screws, silvered and black glass mirrors, and an extra double mirror, by which the pencil of light may be thrown in any desired direction.

-276.

275.

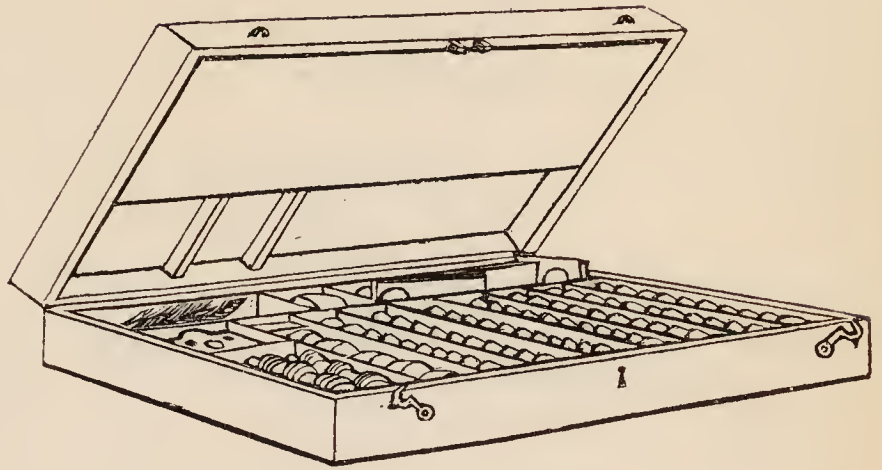
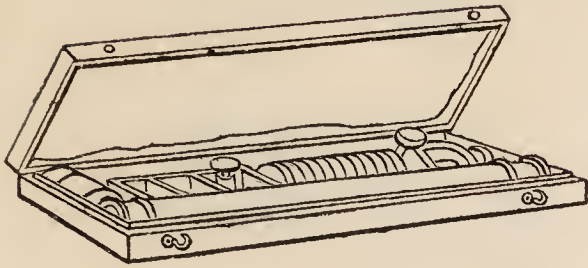

275. Apparatus for examining the coloured fringes formed in the shadows of bodies by diffraction when placed in the light diverging from a luminous point: in case with telescope, &c. complete, £2 12s. 6d.
276. Superior Apparatus for examining the phænomena formed by diffraction in the focus of an object-glass of a telescope, when the aperture is limited to small orifices of various figures, and also when gratings of various constructions are applied: in mahogany case without telescope, £8 8s.
277. Microscopic Apparatus for investigating the phænomena of conical refraction at the optic axes of biaxial crystals fitted with crystals of arragonite: in case complete, £1 11s. 6d.

MAGIC LANTERNS.

278. Magic Lantern, with oil lamp, condensing lens, and tin sliding tube for adjusting the focus, showing well-defined images 3 feet high on the screen, 7s. 6d.; with a dozen painted sliders, 15s.
279. Magic Lantern, with oil lamp, 2-inch bull's-eye condensing lens, tin sliding tube for adjusting the focus, and showing well-defined images 4 feet high on the screen, 12s.; with a dozen painted sliders, £1 3s.
280. Magic Lantern, with oil lamp, 2½-inch bull's-eye condensing lens, and tin sliding tube for adjusting the focus, and showing well-defined images 5 feet high on the screen, 18s.; with a dozen painted sliders, £2 2s.
281. Magic Lantern, with oil lamp, 4-inch bull's-eye condensing lens, and tin sliding tube for adjusting the focus, and showing well-defined images 6 feet high on the screen, £1 11s. 6d.

PHANTASMAGORIA LANTERNS.

282. Phantasmagoria Lantern, with spring front for holding the painted sliders, Argand lamp, pair of 3-inch diameter condensing lenses, double object lens, brass sliding tubes for the more correctly adjusting the focus, and showing well-defined images 7 feet high on the circular screen, £2 10s.
283. Phantasmagoria Lantern, with spring front for holding the paintings, improved fountain Argand lamp, pair of 3½-inch diameter condensing lenses, double object-glass, brass sliding tubes for the more equably adjusting the focus, and showing well-defined images of the moving astronomical diagrams 8 feet diameter on a circular screen, £3 13s. 6d.
284. Ditto, with rack and pinion, £5 5s.

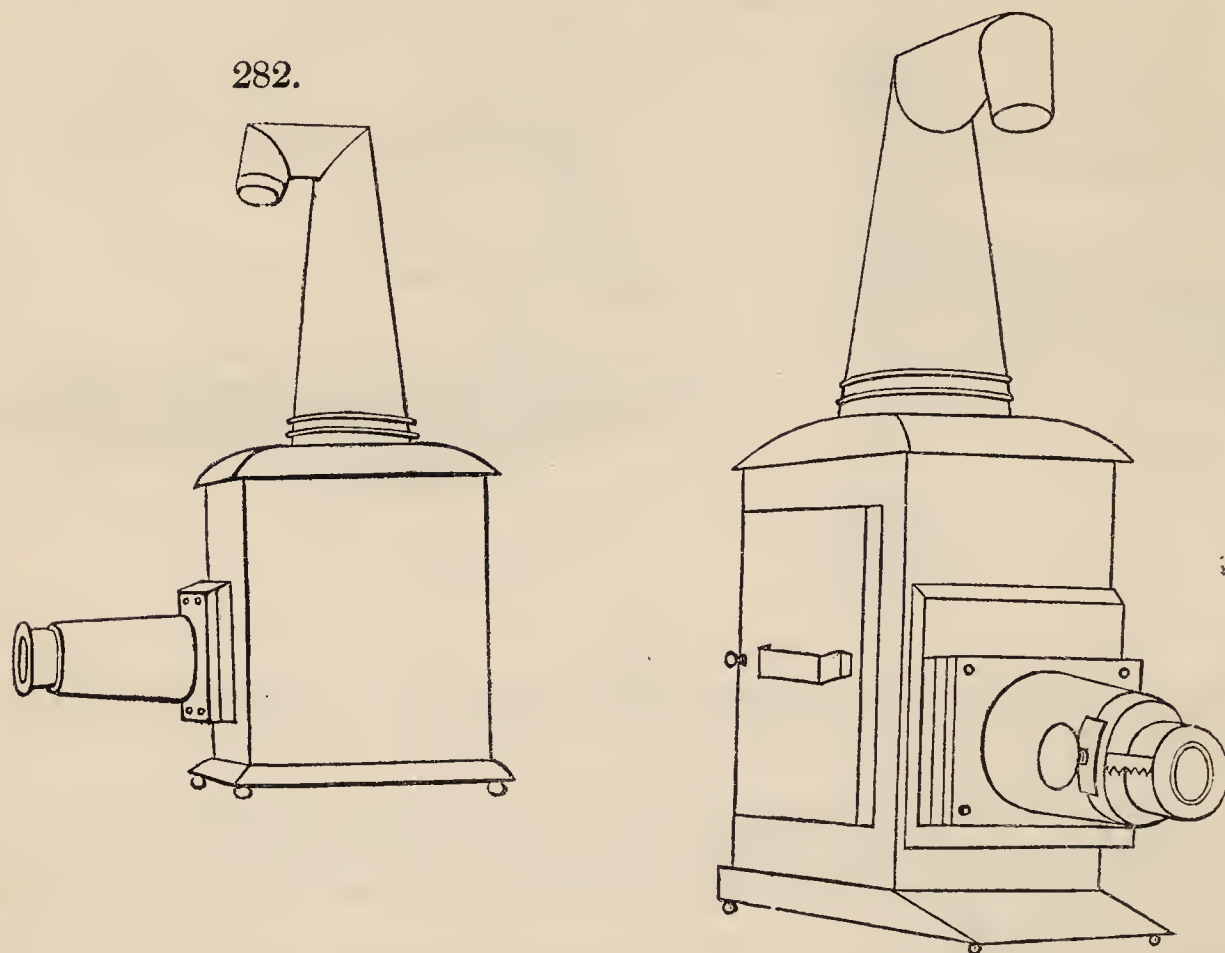

- 282.
285. Best Phantasmagoria Lantern, with spring front for holding the painted sliders, Argand lamp, pair of 4-inch diameter condensing lenses, double object-glass, brass sliding tubes for the more accurately adjusting the focus, and showing well-defined images of the moving astronomical diagrams 10 feet diameter on a circular screen, £5 5s.
286. Best Phantasmagoria Lantern, with spring front for holding the painted sliders, extra large fountain Argand lamp, pair of 4-inch diameter condensing lenses, double object-glass, brass sliding tubes furnished with rack and pinion movements for the more accurately adjusting the focus, and showing well-defined images of the moving astronomical diagrams 10 feet diameter on a circular screen, £6 6s.
287. Best Phantasmagoria Lantern, with spring front for holding the painted sliders, extra large fountain Argand lamp, pair of 4 $\frac{3}{4}$ -inch condensing lenses, double object-glass, brass sliding tubes furnished with rack and pinion movements for the more accurately adjusting the focus, and showing well-defined images of the moving astronomical diagrams 13 or 14 feet diameter on the circular screen, £7 7s.
288. Microscopic Apparatus adapted to Lanterns for exhibiting by means of the oil lamp-light, magnified images on a screen, prepared transparent objects, consisting of insects, their wings, scales of fishes, feathers, ferns, and living aquatic animals. Microscope and set of objects complete, £1 11s. 6d.
289. Superior Phantasmagoria, with mahogany lantern, japanned tin cover and top, pair of 6-inch condensing lenses, compound object-glass, brass sliding tubes fitted with rack and pinion movements for accurate adjustment of the focus. This form of lantern is expressly arranged for illumination by oxyhydrogen lime-light, and may be fitted either on a tripod or tressel stand, £10 10s.
290. Oxyhydrogen Lime-light Apparatus, fitted to the pair of mahogany lanterns for Dissolving Views. It consists of large caoutchouc cloth gas-bags; strongly-hinged pressure boards; India-rubber flexible tubes, each 10 feet long, furnished with brass coupling or union joints; improved arrangement of the two oxyhydrogen blowpipes and lime holders; leaden retort and glass purifier fitted with flexible metallic pipes for generating hydrogen gas; iron retort and metallic pipes for preparing oxygen gas, £14 14s. to £21.

291 to 294.

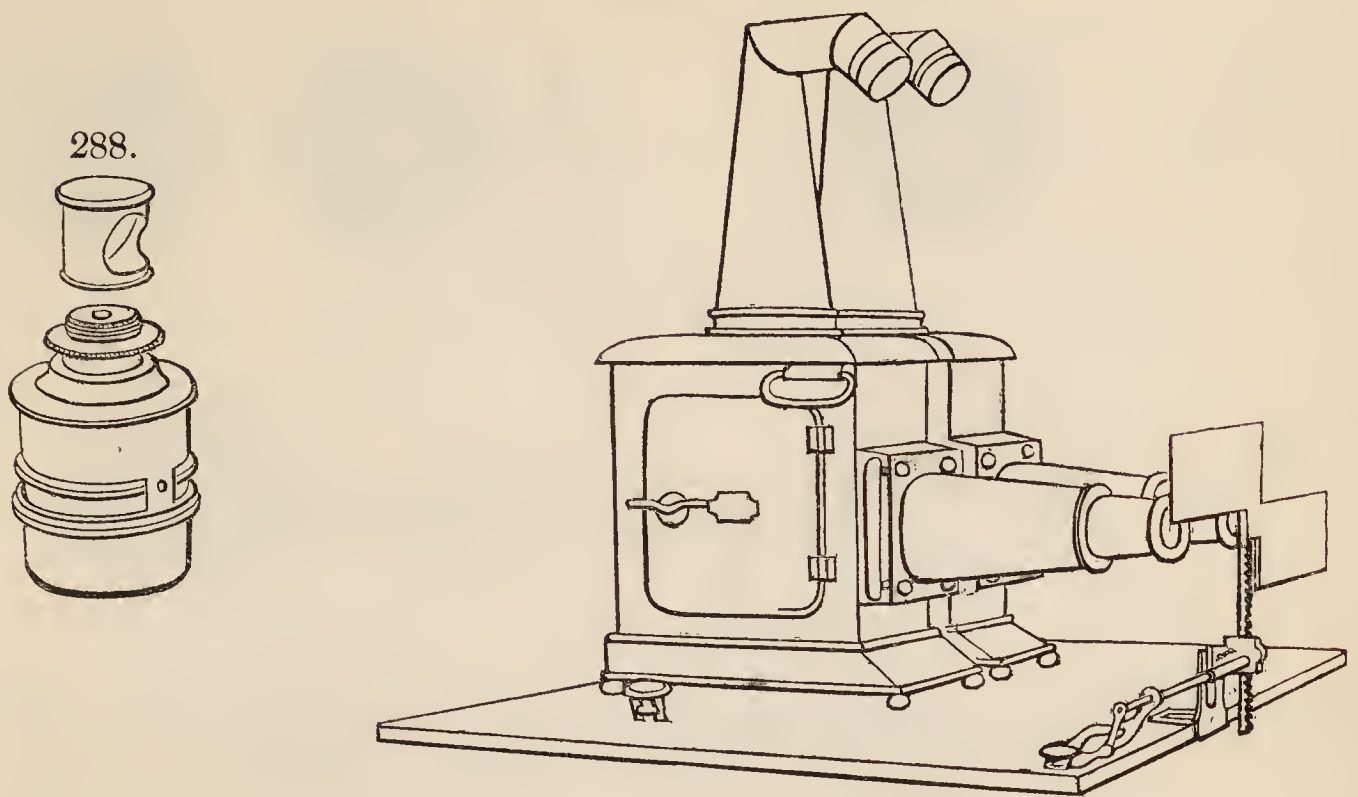

LANTERNS WITH DISSOLVING APPARATUS.

291. Dissolving Apparatus fitted to two Phantasmagoria Lanterns. No. 282 with spring fronts for holding the painted sliders, Argand lamp, pair of 3-inch diameter condensing lenses, double object-glass, brass sliding tubes for the more equably adjusting the focus, and showing well-defined views 7 feet diameter on the circular screen, £6.
292. Dissolving Apparatus fitted to two Phantasmagoria Lanterns. No. 283 with spring fronts for holding the painted sliders, improved fountain Argand lamp, pair of 3½-inch diameter condensing lenses, double object-glass, brass sliding tubes for the more smoothly adjusting the focus, and exhibiting well-defined views 8 feet diameter on the circular screen, £8 8s.
293. Dissolving Apparatus fitted to two Phantasmagoria Lanterns. No. 285 with spring fronts for holding the painted sliders, improved fountain Argand lamp and silver plated reflector, pair of 4-inch diameter condensing lenses, double object-glass, brass sliding tubes for the more smoothly adjusting the focus, and exhibiting well-defined views 10 feet diameter on a circular screen, £11 11s.
294. Dissolving Apparatus fitted to two Phantasmagoria Lanterns. No. 287 with spring fronts for holding the painted sliders, extra-large fountain Argand lamp, pair of 4¾-inch diameter condensing lenses, double object-glass, brass tubes furnished with rack and pinion movements for the more accurately adjusting the focus, and exhibiting well-defined views 13 feet diameter on the circular screen, £15 15s.
295. Dissolving Apparatus fitted to two mahogany Lanterns, with japanned tin covers, pair of 6-inch diameter condensing lenses, double object-glass, brass tubes furnished with rack and pinion movements for accurate adjustment of the focus, and exhibiting well-defined views 16 feet diameter on the circular screen, £23.

COMIC GLASS SLIDERS.

296. Glass Sliders, painted with a variety of humorous subjects to suit Lantern No. 278, 7s. 6d. per dozen.
297. Glass Sliders, painted with different comic subjects to suit Lantern No. 279, 11s. per dozen.
298. Glass Sliders in mahogany frames, with a diversity of humorous and spectral subjects painted in a superior manner, adapted for Lanterns Nos. 280 and 282, 2s. each slider, or 24s. per dozen.

295.

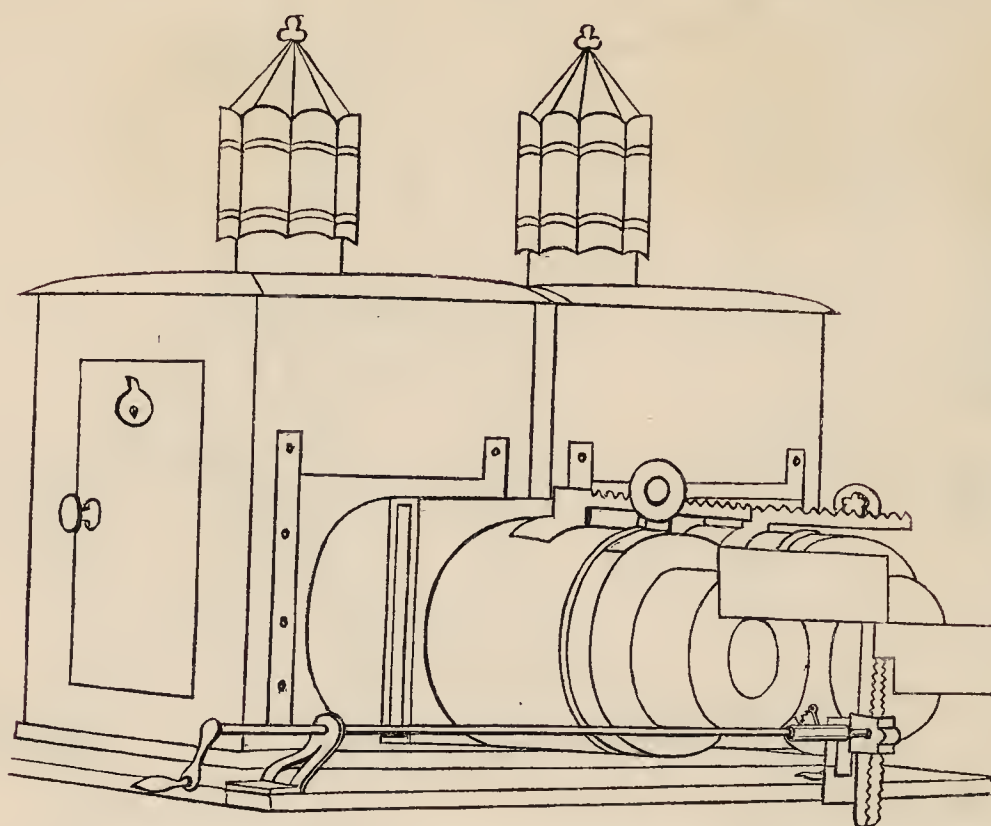

299. Glass Sliders in mahogany frames, with a variety of humorous and spectral subjects painted in a superior manner, adapted for Lanterns Nos. 283 to 287, 4s. 6d. each slider, or 54s. per dozen.
300. Shifting Glass Sliders, painted with a diversity of highly comic or spectral subjects, so that the magnified images on the screen may appear with life and activity by repeatedly changing the parts of the image, making it appear as if the eyes rolled, the mouth opened and closed, and the figures tumbled or danced. To suit Lanterns 280 and 282, 2s. 6d. each slider.
301. Shifting Glass Sliders, painted with numerous comic devices and spectral subjects, so that the magnified images on the screen may be made to move as if they possessed life and motion, and represent both whimsical and distorted attitudes. To suit Lanterns Nos. 283 to 287, 4s. 6d. each slider.

ASTRONOMICAL SLIDERS.

302. Set of 12 Glass Sliders, painted with astronomical diagrams to illustrate the phænomena of the solar system, the theory of eclipses, phases of the moon, the tides, cause of the seasons, telescopic views of the moon, remarkable comets, constellations and planets. In a case, with a book of description and explanation, and adapted for No. 279 Lantern, 18s.
303. Set of 13 Glass Sliders, painted with astronomical diagrams to illustrate the phænomena of the solar system, the theory of eclipses, phases of the moon, the tides, cause of the seasons, telescopic views of the moon, remarkable comets, constellations and planets. In a case, with a book of description and explanation, to suit Lanterns Nos. 280 and 282, £1 15s.
304. Set of 12 Glass Sliders, painted with astronomical diagrams to illustrate the phænomena of the solar system, the theory of eclipses, phases of the moon, the tides, cause of the seasons, telescopic views of the moon, remarkable comets, constellations and planets. Packed in a case, with a book of description and explanation, to suit Nos. 283 to 287 Lanterns, £3 3s.
305. Set of 9 Glass Sliders, with painted astronomical diagrams, furnished with brass rack and pinion movements, so that the magnified images may be made to revolve and exhibit in motion the phases of the moon, solar system, eclipses, the nature of the tides and seasons, the diurnal and annual rotation of the earth, &c., for the illustration of a familiar discourse on popular astronomy. Packed in a case to suit Lanterns Nos. 282 to 287, £5 10s. and £6 10s.

304.



305.



313.

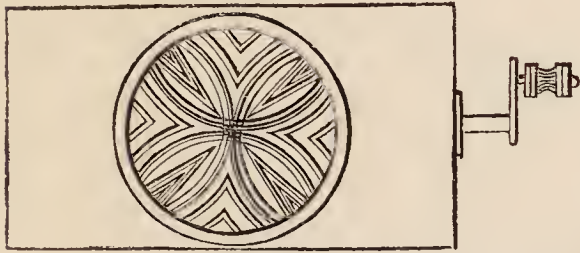

314.

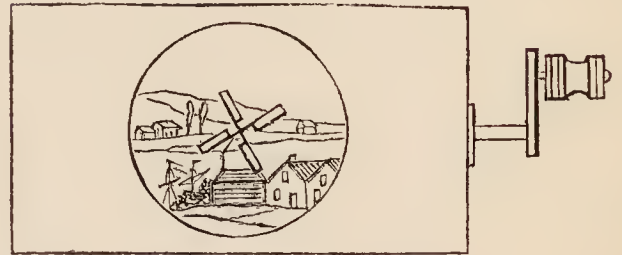

306. Set of 5 Rack and Pinion Sliders and 12 Plain Sliders, painted with astronomical diagrams to illustrate the general and most interesting phenomena of astronomical science, in a box, £5 15s. 6d.
307. Single Rack and Pinion Sliders, with painted astronomical subjects, each 11s. to 17s.

DISSOLVING SLIDERS.

308. Dissolving Glass Sliders, with circular paintings adapted for single representation on the screen, or for dissolving effects representing landscapes, remarkable public buildings, the exterior and interior of cathedrals and churches. To suit Lanterns Nos. 282 and 283, 5s. 6d. to 9s. each slider.
309. Dissolving Glass Sliders, with circular paintings for single exhibition on the screen, or for dissolving effects to show landscapes, remarkable edifices, the exterior and interior of churches. To suit Lanterns Nos. 284 to 287, 7s. 6d. to 16s. 6d. each slider.
310. Dissolving Glass Sliders, prepared for showing dissolving effects with lanterns illuminated by the oxyhydrogen lime-light. The quality of the paintings is necessarily very superior to those employed in the exhibition with the Argand lamp; the subjects are more elaborate and much more highly finished, in consequence of the great difference in the intensity of the oxyhydrogen lime-light, £1 1s. to £10 10s. Panoramic and Dioramic effects may be produced by the sliders.
- *.* Glass Sliders of all sizes and subjects painted to order.
311. Sets of painted Glass Sliders, to illustrate with the Phantasmagoria Lantern the most interesting objects in the study of natural history, geology and botany, 3s. to 6s. each.
312. Glass Sliders, painted with portraits of royal personages, naval and military commanders, and other eminent men, to suit all the variety of lanterns, for exhibition singly, or by the dissolving apparatus, 10s. to £2 2s.
313. Chromatropé Sliders for artificial fireworks, 10s. 6d., 15s., £1 2s.
314. Moving Rackwork Sliders, showing windmills, waterwheels, fountains, &c. in motion, 16s. and upwards.
315. Prepared Semi-Transparent Screens and Rollers for receiving the magnified images, projected by the Phantasmagoria Lantern on one side of the screen, which are rendered distinctly visible to persons situated on the opposite side, whereby the illusion is considerably increased, and the exhibition more striking and wonderful. From 5 feet square, £2 2s. to £4 14s. 6d.
316. Opake Screens and Rollers, with a dead-white circular disc, of a preparation free from glossy materials, which is found to show the magnified images in a more clear and brilliant manner than when exhibited on an ordinary white painted surface. From 5 feet square, £2 2s. to £5 5s.
317. Portable Deal Tressels, or Tripod Stand for pairs of lanterns, with dissolving apparatus, £1 5s. to £2 2s.
318. A Strong Iron-bound Deal Case with iron handles to contain a pair of lanterns, and arranged so as to form a stand when the lanterns are in use, with the dissolving apparatus attached to the lid, 18s. to £1 10s.



Price 2s. 6d.,

WATKINS AND HILL'S

POPULAR INTRODUCTION

TO

EXPERIMENTAL CHEMISTRY;

CONTAINING

**A DESCRIPTION OF THE APPARATUS REQUIRED FOR CONDUCTING
THOSE PROCESSES WHICH FIRST CLAIM THE ATTENTION
OF CHEMICAL STUDENTS, ELUCIDATED BY NUMEROUS
FIGURES AND EASY EXPERIMENTS.**

LONDON:
PRINTED BY RICHARD TAYLOR AND WILLIAM FRANCIS,
RED LION COURT, FLEET STREET.

Already published by

WATKINS AND HILL.

Price 6d. each.

DESCRIPTIVE CATALOGUES

OF

ELECTRICAL INSTRUMENTS.

Illustrated by Ninety-seven Engravings.

VOLTAIC AND THERMO-ELECTRIC
INSTRUMENTS.

Illustrated by Seventy-eight Engravings.

MAGNETIC AND ELECTRO-MAGNETIC
INSTRUMENTS.

Illustrated by Ninety-six Engravings.

HYDROSTATIC, HYDRAULIC, PNEUMATIC, AND
ACOUSTIC INSTRUMENTS.

Illustrated by One Hundred and Twelve Engravings.